

TURBO-III-A DEHIDER

INCLUDING: OPERATION, INSTRUCTION, INSTALLATION, MAINTENANCE AND PARTSBOOK

**IMPORTANT: READ THIS MANUAL CAREFULLY BEFORE INSTALLING, OPERATING OR
SERVICING THIS TOOL.**

DEHIDER

TOOL DATA

MODEL: TURBO-III-A DEHIDER
ASSEMBLY NO: 6303000
TYPE: AIR OPERATED
NET WEIGHT: 2 LBS 12 OZ (1.26 KG)
INLET AIR PRESSURE: 90 P.S.I. (6 BARS)

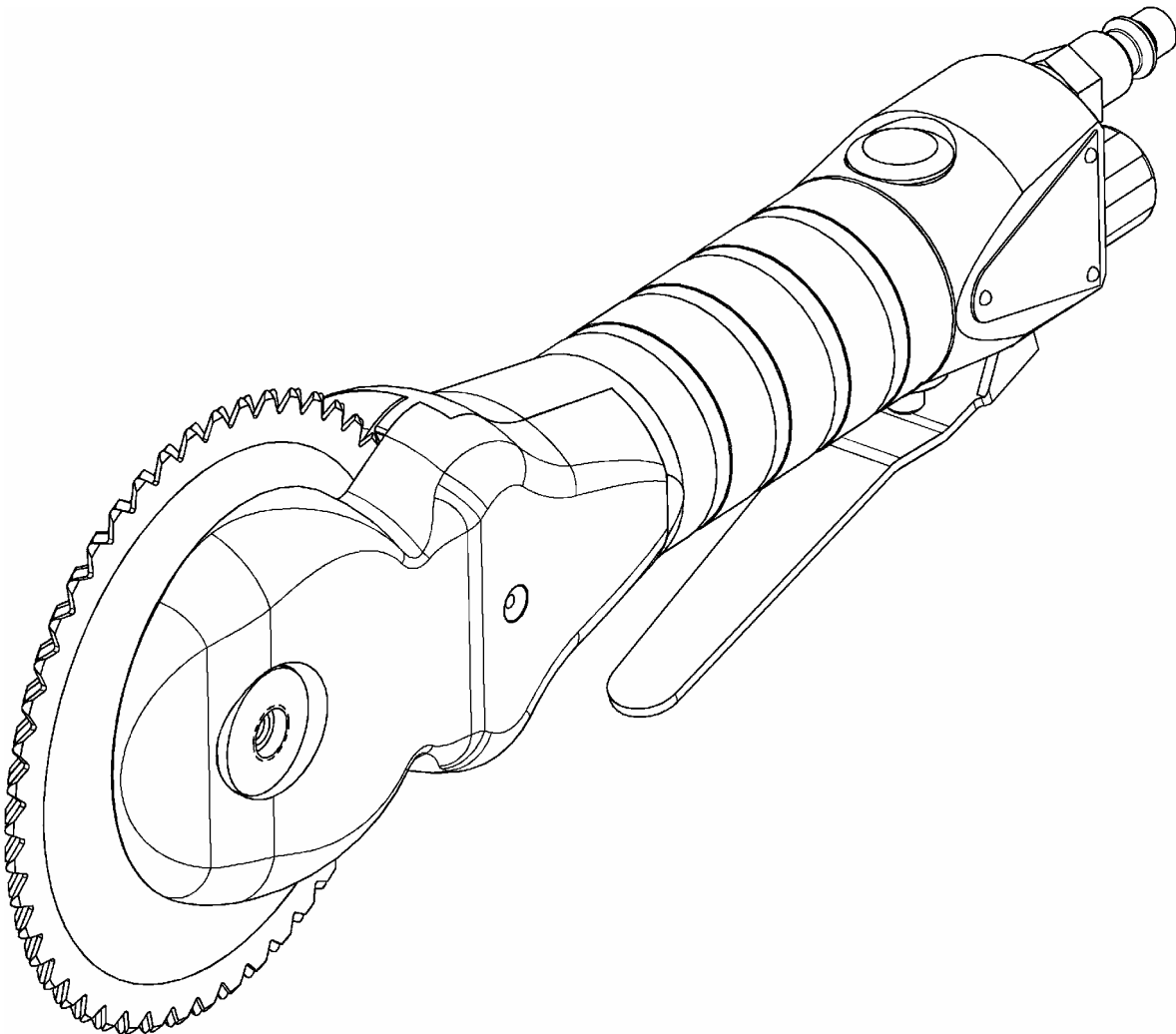

**WARNING**

= Hazards or unsafe practices which could result in severe personal injury, death or substantial property damage.

**CAUTION**

= Hazards or unsafe practices which could result in minor personal injury, product or property damage.

**NOTICE**

= Important installation, operation or maintenance information.

OPERATING AND SAFETY INSTRUCTIONS

**WARNING**

DO NOT OPERATE THIS TOOL UNTIL YOU HAVE READ AND UNDERSTOOD THE SAFETY INSTRUCTIONS AND OPERATING MANUALS.

**WARNING**

DO NOT OPERATE THIS TOOL UNTIL YOU HAVE RECEIVED TRAINING IN THE HANDLING, OPERATION AND USE OF THIS TOOL.

**WARNING**

STOP USING A MALFUNCTIONING OR DEFECTIVE TOOL IMMEDIATELY. REPORT ANY PROBLEMS OR DEFECTS TO YOUR SUPERVISOR FOR REMOVAL OF THE TOOL FROM SERVICE.

**WARNING**

DO NOT ATTEMPT TO REPAIR THE TOOL YOURSELF.

**WARNING**

DO NOT ALLOW UNAUTHORIZED PERSONS TO USE TOOL.

**WARNING**

REMOVE AND DISCONNECT POWER FROM THE TOOL WHEN TOOL IS LEFT UNATTENDED OR IS NOT IN USE.

**WARNING**

NEVER TIE DOWN, BYPASS, ALTER OR MODIFY THE ACTIVATING SWITCHES OR TRIGGERS OF THIS TOOL.

**WARNING**

NEVER MAKE ALTERATIONS OR MODIFICATIONS TO THIS TOOL.

**WARNING**

BE CONSTANTLY AWARE AND ALERT FOR UNSAFE CONDITIONS AND REPORT THEM IMMEDIATELY TO YOUR SUPERVISOR.

**WARNING**

NEVER PLACE YOUR HAND OR ANY PART OF YOUR BODY IN THE CUTTING PATH OF THE TOOL.

**WARNING**

NEVER ALLOW ANYONE ELSE TO PLACE THEIR HANDS OR ANY PART OF THEIR BODY IN THE CUTTING PATH OF THE TOOL.

**WARNING**

DO NOT ACTIVATE CONTROL SWITCHES OR TRIGGERS OF THIS TOOL UNLESS YOU INTEND TO TEST OR OPERATE THIS TOOL.

**WARNING**

DO NOT USE THIS TOOL FOR ANY PURPOSE OTHER THAN IT'S INTENDED PURPOSE.

**CAUTION**

WHEN OPERATING THIS TOOL WEAR THE PROTECTIVE GEAR AND SAFETY EQUIPMENT SUPPLIED TO YOU.

**WARNING**

THE NOISE EMISSION (SOUND PRESSURE LEVEL) AT THE WORKSTATION MAY EXCEED 85 dB (A). EAR AND SOUND PROTECTION GEAR IS REQUIRED.

OPERATING INSTRUCTIONS

⚠ WARNING ONLY TRAINED PERSONNEL ARE TO OPERATE THIS TOOL.

1. HOLD TOOL FIRMLY IN HAND WITH TRIGGER LEVER IN POSITION TO BE ACTIVATED BY FINGERS.
2. SQUEEZE TRIGGER TO ACTIVATED TOOL, RELEASE TRIGGER TO DEACTIVATE TOOL.
3. POSITION TOOL AND PERFORM CUTTING OPERATION.
4. DO NOT LAY TOOL DOWN WHEN TOOL IS NOT BEING USED. PLACE TOOL IN BRACKET (PART NO. 630100). BRACKET SHOULD BE MOUNTED IN A CONVENIENT LOCATION NEAR OPERATOR.
5. TOOL REQUIRES 40 S.C.F.M. OF AIR @ 90 P.S.I. AIR PRESSURE.

MAINTENANCE

⚠ WARNING ONLY TRAINED AND QUALIFIED PERSONNEL ARE TO PERFORM MAINTENANCE AND SERVICE TO THIS TOOL.

1. FILL LUBRICATOR WITH KENTMASTER AIR MIST OIL (PART NO. 7903050). SET DRIP RATE ACCORDING TO INSTRUCTIONS SUPPLIED.
2. TOOL REQUIRES GREASING AFTER EVERY 3 TO 4 HOURS OF OPERATION. GREASE THREE (3) LOCATIONS USING KENTMASTER GREASE GUN (PART NO. 450147) AND GREASE (PART NO. 790307).
3. FLUSH AIR MOTOR AT END OF EACH DAY'S USE BY SQUIRTING A FEW SQUIRTS OF KENTMASTER AIR OIL MIST (PART NO. 790305) DIRECTLY INTO THE AIR INLET PORT. RUN TOOL A FEW SECONDS TO COAT AND PROTECT THE AIR MOTOR AND INTERNAL PARTS OF TOOL.

BLADE REMOVAL AND CLEANING

⚠ WARNING

ALWAYS DISCONNECT POWER SUPPLY FROM TOOL BEFORE INSTALLING OR REMOVING BLADE FROM TOOL.

⚠ WARNING

ALWAYS WEAR WIRE MESH GLOVES WHEN INSTALLING OR REMOVING BLADE FROM TOOL.

1. REMOVE COVER SCREW (ITEM NO. 1, FIG. NO. 1).
2. REMOVE PARTS (ITEM NOS. 2-7, FIG. NO. 1).
3. CLEAN ALL PARTS REMOVED WITH SOAP AND WATER.
4. SHARPEN BLADES WHEN NECESSARY AND LUBRICATE ALL PARTS.
5. REASSEMBLE ALL PARTS IN REVERSE ORDER.

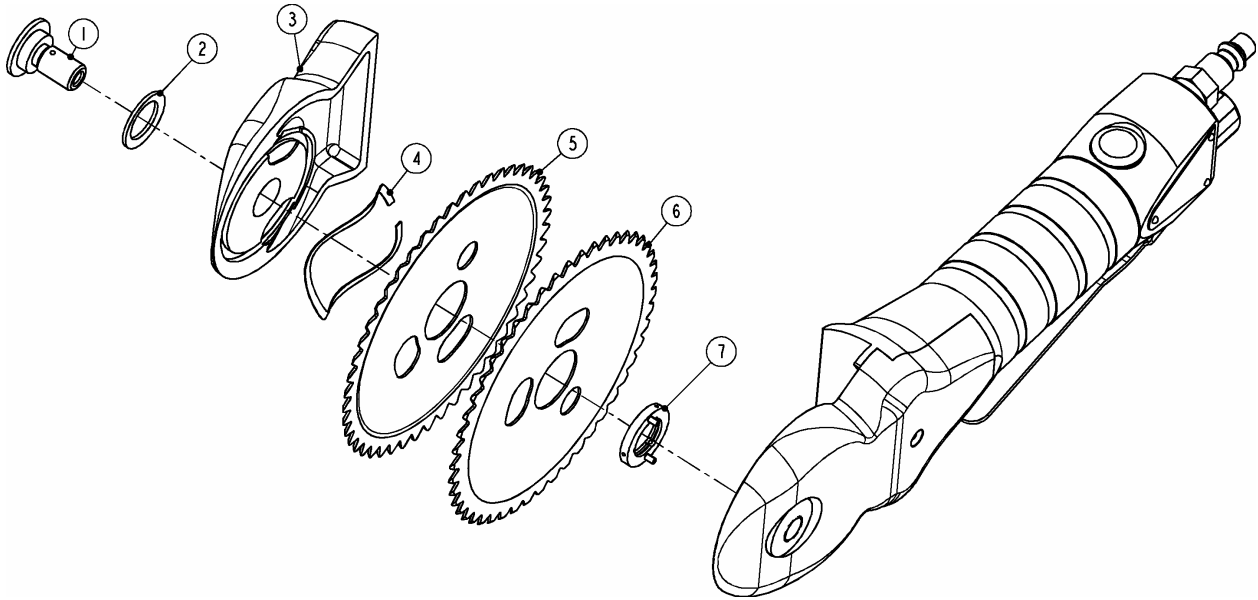

Figure 1 BLADE REMOVAL

KENTMASTER MFG. CO., INC. 1801 SOUTH MOUNTAIN AVE., MONROVIA, CALIFORNIA 91016 UNITED STATES OF AMERICA

☎ TELEPHONE: (626) 359-8888 FAX: (626) 303-5151

SERVICE

1. KEEP GOOD RECORDS OF ALL SERVICE ACTIVITY AND INCLUDE TOOL IN PREVENTIVE MAINTENANCE PROGRAM.
2. USE ONLY GENUINE KENTMASTER REPLACEMENT PARTS TO ASSURE PROPER PERFORMANCE OF TOOL.
3. CONTACT THE KENTMASTER SUPPLIER NEAREST YOU FOR PARTS AND CUSTOMER SERVICE INFORMATION.
4. SAFETY DATA FOR LOCTITE CORPORATION PRODUCTS "LOCQUIC - PRIMER N" AND "LOCTITE - 272"



EYE IRRITANT, MAY IRRITATE SENSITIVE SKIN. CONTAINS METHACRYLATE ESTER. IN CASE OF EYE CONTACT, FLUSH WITH WATER FOR FIFTEEN (15) MINUTES; GET MEDICAL ATTENTION. WASH AFTER SKIN CONTACT. IN CASE OF SKIN IRRITATION, DISCONTINUE CONTACT WITH PRODUCT. TO AVOID SKIN CONTACT, USE THE APPLICATOR NOZZLE PROVIDED. OTHER APPLICATORS ARE AVAILABLE FROM LOCTITE CORPORATION.
KEEP MATERIAL AWAY FROM CHILDREN.

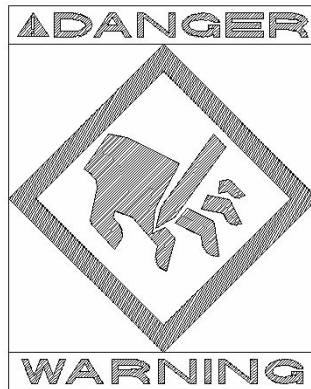

PARTS BOOK
MODEL TURBO-III-A DEHIDER

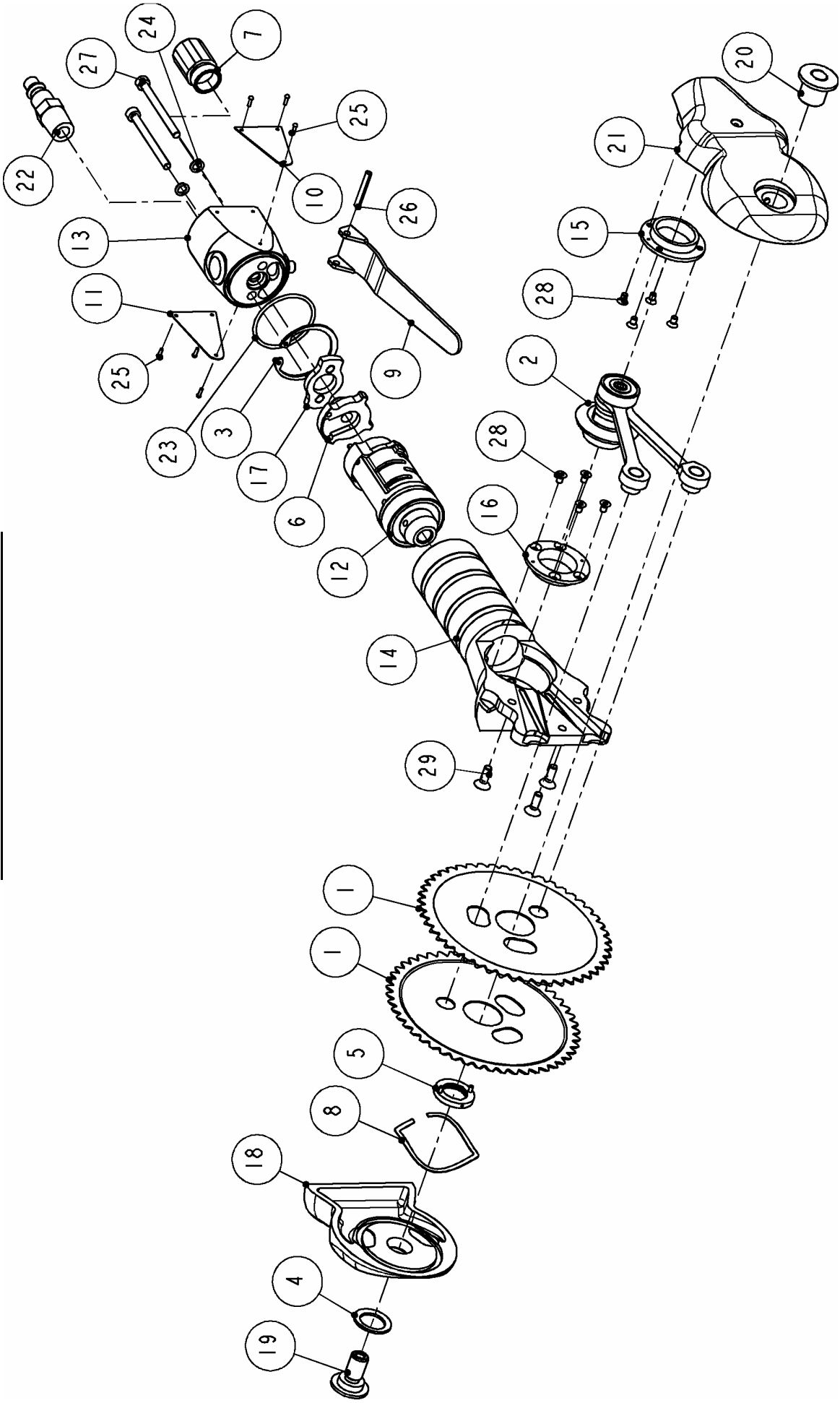

Figure 2 6303000: MODEL TURBO-III-A

KENTMASTER MFG. CO., INC. 1801 SOUTH MOUNTAIN AVE., MONROVIA, CALIFORNIA 91016 UNITED STATES OF AMERICA

☎ TELEPHONE: (626) 359-8888 FAX: (626) 303-5151

LOCTITE CORP. PRODUCTS "LOCQUIC – PRIMER N" AND ADHESIVE "LOCTITE 242" MUST BE APPLIED TO ITEMS 14, 21, 28, 29 FIG.2, PRIOR TO ASSEMBLY.

FOR "PRIMER – N":

- A. CLEAN PARTS
- B. SPRAY THREADS ON SCREWS AND MATING PARTS WITH "PRIMER – N"
- C. ALLOW PRIMER TO DRY 3-5 MINUTES

FOR "LOCTITE 242":

- A. CLEAN AND DRY PARTS
- B. APPLY 242 TO THREADS ON SCREWS AND MATING PARTS
- C. ASSEMBLE AND LET STAND FOR 30 MINUTES

6303000: DEHIDER TURBO-III-A			
ITEM	PART #	DESCRIPTION	QTY
1	6300370	BLADE SET (110mm)(4.33") -includes two blades - STANDARD	1
	6300390	BLADE SET (100mm)(3.98") -includes two blades - OPTIONAL	1
2	6302810	ASSEMBLY, ECCENTRIC SHAFT, 0.062" OFFSET - STANDARD	1
	6303170	ASSEMBLY, ECCENTRIC SHAFT, 0.042" OFFSET - OPTIONAL	1
3	5001310	RETAINING RING	1
4	6300560	WASHER	1
5	6300580	BLADE SPACER	1
6	6300740	AIR SUPPLY RING	1
7	6300840	MUFFLER	1
8	6302360	SPRING LOAD	1
9	6302430	LEVER	1
10	6302440	LABEL - KENTMASTER	1
11	6302450	NAME PLATE - TURBO III	1
12	6302610	AIR MOTOR ASSEMBLY	1
13	6302630	VALVE ASSEMBLY	1
14	6302740	HOUSING, FRAME	1
15	6302770	FLANGE COVER	1
16	6302780	FLANGE, FRAME	1
17	6302820	LOCK RING, VALVE	1
18	6302830	COVER	1
19	6302880	SCREW, COVER LOCK	1
20	6302910	INSERT	1
21	6302920	COVER, DRIVE SIDE (W/GREASE FITTING)	1
22	7034070	MALE PLUG	1
23	7680270	O-RING	1
24	8506590	WASHER	2
25	8640030	DRIVE SCREW	6
26	8653140	PIN	1
27	9208140	SCREW	2
28	9234020	SCREW	8
29	9238040	SCREW	3

Figure 3 BOM FOR MODEL TURBO-III-A

ECCENTRIC SHAFT ASSEMBLY

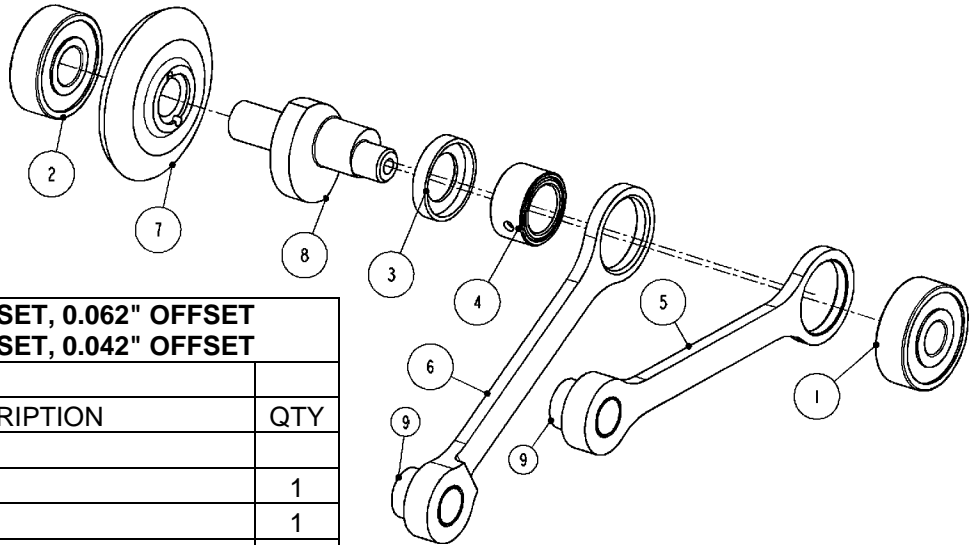

6302810: ECCENTRIC SHAFT SET, 0.062" OFFSET 6303170: ECCENTRIC SHAFT SET, 0.042" OFFSET			
ITEM	PART #	DESCRIPTION	QTY
1	3070370	BEARING	1
2	3071380	BEARING	1
3	6300650	SPACER	1
4	6300850	NEEDLE BEARING ASSEMBLY	1
5	6302540	DRIVE LINK, RIGHT	1
6	6302550	DRIVE LINK, LEFT	1
7	6302790	BEVEL GEAR	1
8	6303150	SHAFT, 0.062" OFFSET-STANDARD	1
	6303160	SHAFT, 0.042" OFFSET-OPTIONAL	1
9	6302530	PIN, BLADE DRIVE – (PIN ONLY)	2

DISASSEMBLY AND ASSEMBLY:

REMOVE MOTOR AND PINION GEAR ASSEMBLY (ITEM 12, FIG 2.) PRIOR TO REMOVING SHAFT ASSEMBLY (ITEM 2, FIG. 2). REMOVE VALVE ASSEMBLY (ITEM 13, FIG. 2) AND RETAINING RING (ITEM 3, FIG. 2). MOTOR AND PINION ASSEMBLY WILL SLIDE OUT. REASSEMBLE IN REVERSE ORDER.

	<p>STEP 1:</p> <p>PLACE SHAFT ASSEMBLY IN DISASSEMBLY TOOL (NO. 450157) AND PRESS OUT SHAFT (ITEM 8, FIG 4.)</p>	<p>LOCTITE CORP. PRODUCTS "LOCQUIC – PRIMER N" AND ADHESIVE "LOCTITE 242" MUST BE APPLIED TO ITEMS 14, 21, 28, 29 FIG.2, PRIOR TO ASSEMBLY.</p> <p>FOR "PRIMER – N":</p> <p>D. CLEAN PARTS</p> <p>E. SPRAY THREADS ON SCREWS AND MATING PARTS WITH "PRIMER – N"</p> <p>F. ALLOW PRIMER TO DRY 3-5 MINUTES</p>
	<p>STEP 2:</p> <p>TO REMOVE BEARING (ITEM 4, FIG 4) AND LINKS, PLACE SHAFT ASSEMBLY IN DISASSEMBLY TOOL (NO. 450157) AND PRESS OUT SHAFT (ITEM 8, FIG 4.)</p>	<p>FOR "LOCTITE 242":</p> <p>D. CLEAN AND DRY PARTS</p> <p>E. APPLY 242 TO THREADS ON SCREWS AND MATING PARTS</p> <p>F. ASSEMBLE AND LET STAND FOR 30 MINUTES</p>

Figure 4 ECCENTRIC SHAFT ASSAMBLY

AIR MOTOR & PINION ASSEMBLY

6302610: AIR MOTOR & PINION ASSEMBLY			
ITEM	PART #	DESCRIPTION	QTY
1	3072380	BEARING	1
2	6300570	SPACER RING	1
3	6300690	CYLINDER, AIR MOTOR	1
4	6300700	VANE	5
5	6300720	PLATE, MOTOR FRONT	1
6	6300890	BEARING	1
7	6302410	END CAP, MOTOR REAR	1
8	6302420	ROTOR, AIR MOTOR	1
9	6302480	PINION GEAR	1
10	8611600	PIN	1

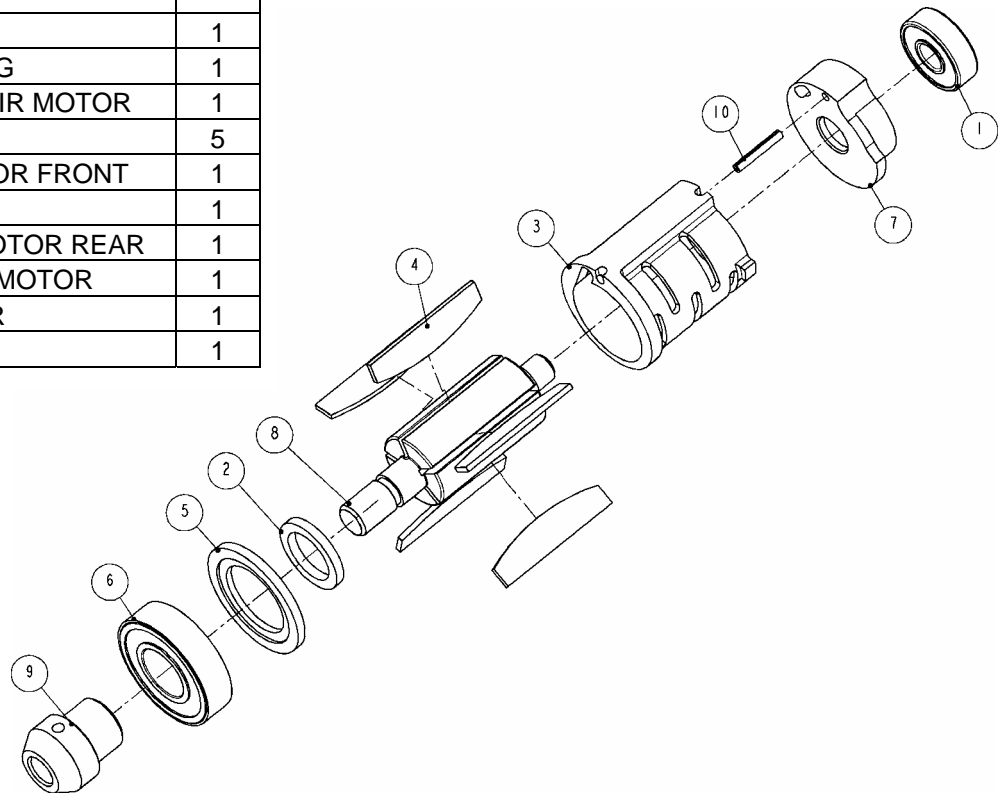

MOTOR DISASSEMBLY

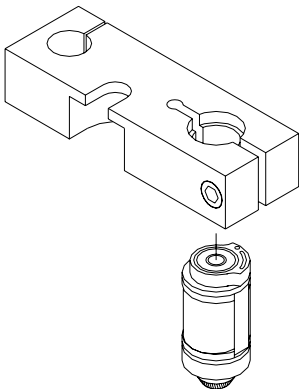

STEP 1:
REMOVE ENDCAP (ITEM 7) BY LOCKING IN LOWER COUNTERBORE OF DISASSEMBLY TOOL (450157). DRIVE END OF ROTOR (ITEM 8) THRU BEARING (ITEM 1) BY USING PIN DRIVER (450153, SEE TOOL SECTION).

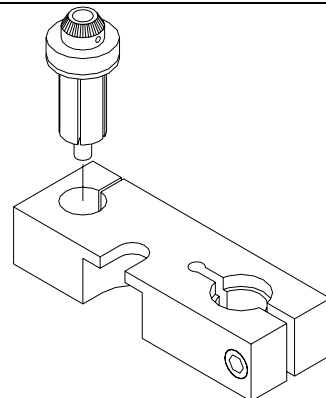

STEP 2:
REMOVE PINION (ITEM 9) BY SLIDING ROTOR INTO KEYED HOLE AND USING SPANNER WRENCH (450155). UNSCREW PINION (RIGHT HAND THREAD). PRESS PINION OUT OF BEARING (ITEM 6) IN ADJACENT HOLE.

Figure 5 AIR MOTOR & PINION ASSEMBLY

VALVE ASSEMBLY

6302630: VALVE ASSEMBLY			
ITEM	PART #	DESCRIPTION	QTY
1	6300770	VALVE PLUG	1
2	6300800	SPRING	1
3	6302570	VALVE STEM	1
4	6302640	BODY, VALVE	1
5	7680080	O-RING	1
6	7680100	O-RING	1
7	7680140	O-RING	1

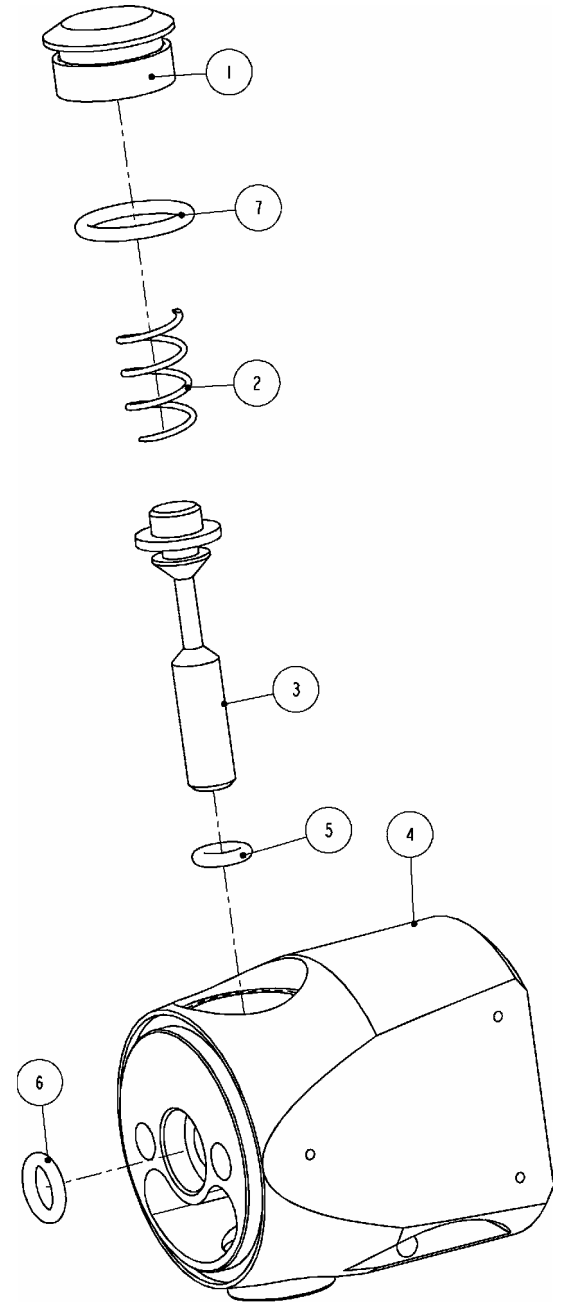
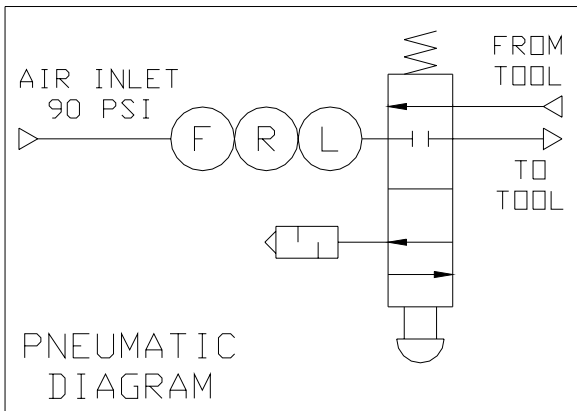
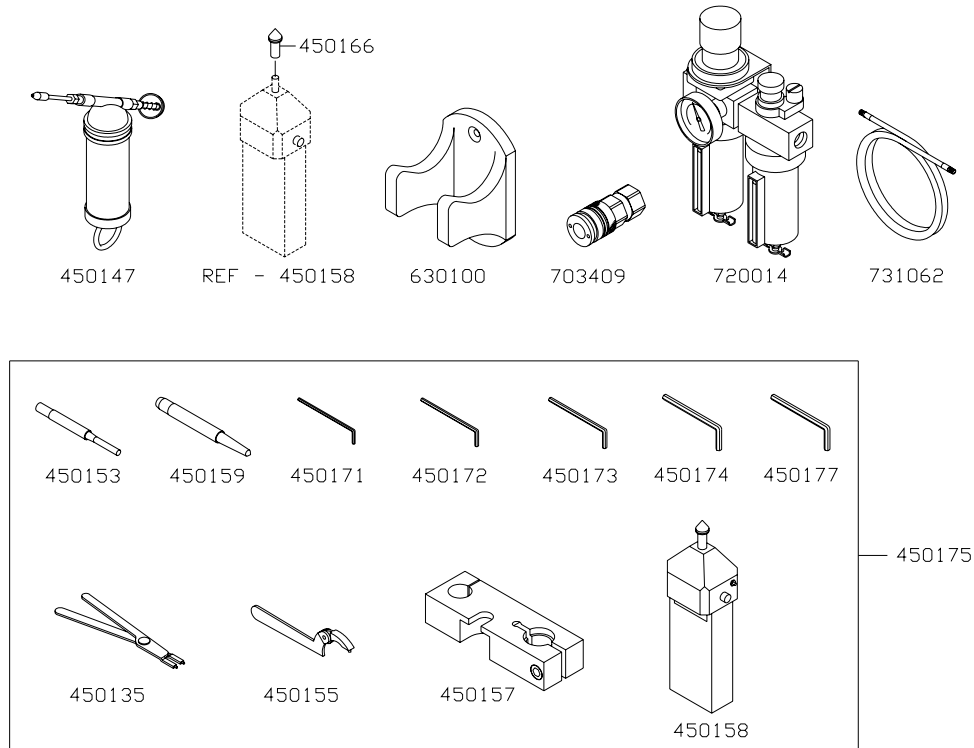

Figure 6 6302630: VALVE ASSEMBLY

MAINTENANCE TOOLS



PART NO.	DESCRIPTION
450135	Pliers
450147	Grease Gun
450153	Pin Driver
450155	Spanner Wrench
450157	Disassembly Tool
450158	Tachometer (Supplied with 1 Conical Tip - No. 450166)
450159	Eccentric Driver
450166	Conical Tip
450171	Hex Wrench (2 mm)
450172	Hex Wrench (2.5 mm)
450173	Hex Wrench (4 mm)
450174	Hex Wrench (6 mm)
450175	Tools - Complete Set (Refer to Picture above for list of tools)
450177	Hex Wrench (10 mm)
630100	Bracket
703409	Socket
720014	Filter-Regulator-Lubricator
731062	Hose Assembly
790304	Air Oil Mist (1 Pint)
790305	Air Oil Mist (1 Gallon)
790306	Air Oil Mist (5 Gallon)
790307	Grease (White Food Grade)(14.5 oz)

Figure 7 MAINTENANCE TOOLS

[ENGLISH]

GENERAL INFORMATION

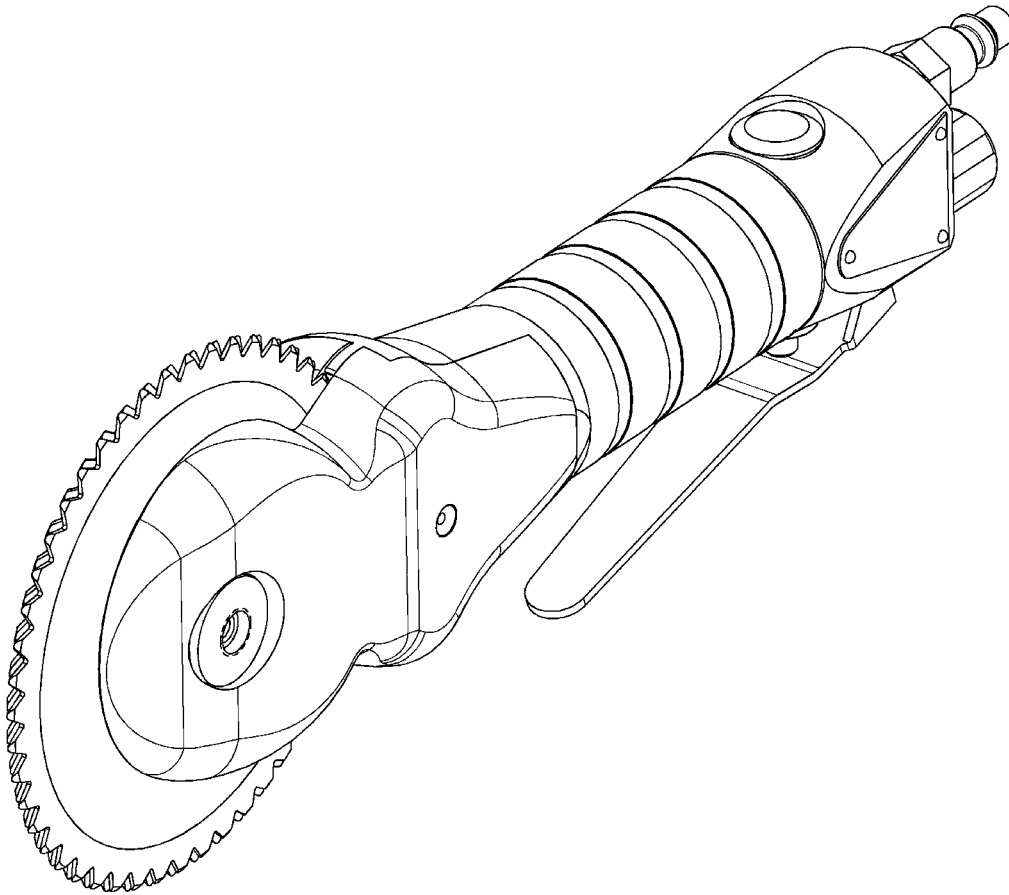

MODELS

TURBO-III-A DEHIDER (6303000)

SERVICE CENTERS

KENTMASTER LTD. (U.K)
16 AVONBANK INDUSTRIAL CENTRE
WEST TOWN ROAD
AVONMOUTH - BRISTOL BS11 9DE
UNITED KINGDOM

☎ TELEPHONE: ++ 44- (0) 117- 9235035
FAX: ++ 44- (0) 117- 9829010

KENTMASTER MFG. CO., INC.
1801 SOUTH MOUNTAIN AVE.
MONROVIA, CALIFORNIA 91016
UNITED STATES OF AMERICA

☎ TELEPHONE: (626) 359-8888
FAX: (626) 303-5151

NOTICE TO EMPLOYER AND PURCHASER OF TOOL
NOTICE TO SAFETY DIRECTOR

You have purchased a powerful tool that, if misused, can cause severe injury and harm to your employees. You must instruct your employees in the safe and proper use of this tool and to follow the safety procedures and instructions that have been supplied by the manufacturer of this tool. Please follow the following instructions.

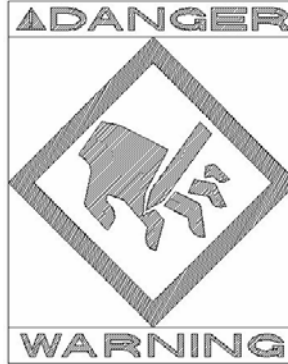

1. Instruct tool operators to test the tool each day before using it to be sure it does not malfunction. Remove and repair any tool that malfunctions.
2. Instruct tool operators to immediately stop using a tool that malfunctions or is defective.
3. Instruct personnel to immediately remove all tools that malfunction. Be sure to disconnect tool from power supply.
4. Instruct all personnel to stay clear of tool, and not to stand or walk in front of, or next to tool when in use.
5. Point out to all personnel the dangers related to the misuse of tool and the importance of following safety procedures and instructions.
6. Do not make, or allow others to make, alterations or modifications to this tool. Replace all lost or illegible labels.
7. Follow all safety, installation and maintenance instructions provided with this tool. Establish proper safety procedures in accordance with local and national requirements to prevent accidental energizing of tool that can cause injuries.
8. If this tool is sold or change in ownership takes place, you must provide the new owner all safety instructions, notices and maintenance instructions you were originally provided. You can obtain additional copies of the instructions from Kentmaster, free of charge upon request.
9. Give copies of instructions to:
 - (A) Tool Operators**
 - (B) Maintenance Supervisor**
 - (C) Clean-up Supervisor**

DECLARATION OF CONFORMITY

DECLARATION OF CONFORMITY

DECLARATION DE CONFORMITE -DECLARACION DE CONFORMIDAD- ERKLARUNG BEZUGLICH EINHALTUNG DER VORSCHRIFTEN
DICHIARAZIONE DI CONFORMITA . CONFORMITEITSVERKLARING

MANUFACTURED BY:

FABRIQUE PAR:
FABRICADA POR:
HERGESTELLTVON:
FABBRICATO DA:
VERVAARDIGD DOOR:

**KENTMASTER MFG CO., INC.
1801 SOUTH MOUNTAIN AVE.
MONROVIA, CALIFORNIA 91016
UNITED STATES OF AMERICA
TELEPHONE (626) 359-8888 FAX (626) 303-5151**

TYPE / SERIES: DEHIDER

TYPE / SERIE:
TIPO / SERIE:
TYP / SERIE:
TIPO / SERIE:
TYPE / SERIE:

MODEL: TURBO-III-A

MODELE:
MODELO:
MODELL:
MODELLO:
MODEL:

SERIAL NO. RANGE: XXXXX

N SERIE: • GAMA DE No. DE SERIE: • SERIEN-NR.-BEREICH: • NUMERI DI SERIE: • SERIENUMMERS:

This product complies with the following European Community Directives:

Ce produit est conforme aux directives de la Communauté europeenne suivantes:
Este producto cumple con las siguientes Directrices de la Comunidad Europea:
Dieses Produkt erfüllt die folgenden Vorschriften der Europäischen Gemeinschaft:
Questo prodotto e conforme alle seguenti direttive CEE:
Dit produkt voldoet aan de volgende EG-richtlijnen:

89/392/EEC, 91/368/EEC, 93/44/EEC, 93/68/EEC

The following Standards were used to verify compliance with the Directives:

Les normes suivantes ont ete utilisees pour verifier la conformite avec les Directives:
Las siguientes Normas se usaron para verificar el cumplimiento de las Directrices:
Folgende Normen wurden angewandt, um erfllung der vorschriften zu bestatigen:
Per verificare la conformita del prodotto alle direttive sono stati usati i seguenti standard:
De volgende normen zijn gebruikt om naleving van de richtlijnen te bevestigen:

EN 292

Approved by: _____

Date: AUG - 1 - 1995

RALPH KARUBIAN MONROVIA, CA. U.S.A
(Engineering Manager) (Directeur technique) (gerente de ingenieria) (verantwortlicher Konstruktionsleiter) (Responsabile tecnico) (ondersteunend technisch mangar)

Kentmaster Worldwide Location

Kentmaster Equipment (Aust) PTY.LTD.

Unit 2,24 Central Court
Browns Plains Qld. 4118
Australia

Telephone: (07) 3806-8400

Fax: (07) 3806-7933

Australia@Kentmaster.com

Kentmaster do Brasil, Ltda.
Av. Dr. Joao Teodoro No. 805
Bairro De Vila Rezende
13405-240 Piracicaba, SP,
Brazil

Telephone #1: (019) 3 413 3113

Telephone #2: (019)983-4973

Fax: (019) 3 413 3113

Brazil@Kentmaster.com

Kentmaster (IRL) LTD.
Benamore, Dublin Road.
Roscrea,
CO, Tipperary,
Ireland

Telephone: (353) 0505-23292

Fax: (353) 0505-23299

Ireland@Kentmaster.com

Kentmaster Equipment (NZ) LTD.
5 Cooper Street
Havelock North
New Zealand

Telephone #1: (64) 6 8777 857

Telephone #2: 0800 KENTMASTER

Fax: (64) 6 8777 858

NewZealand@Kentmaster.com

Kentmaster South Africa (PTY) LTD.

Johannesburg - S. Africa
Unit 54 Sunnyrock Park
Sunrock Close, Germiston
South Africa

Telephone: (27) 11-455-3748

Fax: (27) 11-455-3749

SouthAfrica@Kentmaster.com

Kentmaster (UK) LTD.
Unit 16 Avonbank Ind. Centre
West Town Rd, Avonmouth-Bristol,
BS11 9DE
England

Telephone: (44) 117-923-5035

Fax: (44)-117-932-9010

UK@Kentmaster.com

Kentmaster Mfg. Co., Inc.
1801 South Mountain Ave.
Monrovia, CA, 91016
USA

Telephone #1: (626) 359-8888

Telephone #2: (800) 421-1477

Fax: (626) 303-5151

info@Kentmaster.com

Kentmaster Omaha
4417 South 139th Street
Omaha, NE, 68137
USA

Telephone #1: (402) 896-3355

Telephone #2: (800) 367-3181

Fax: (402) 896-3311

Omaha@Kentmaster.com

INDEX

OPERATING AND SAFETY INSTRUCTIONS..... 2
 OPERATING INSTRUCTIONS..... 3
 MAINTENANCE..... 3
SERVICE 4
PARTS BOOK..... 5
 MODEL TURBO-III-A DEHIDER 5
 ECCENTRIC SHAFT ASSEMBLY 7
 AIR MOTOR & PINION ASSEMBLY 8
 VALVE ASSEMBLY 9
 MAINTENANCE TOOLS 10
DECLARATION OF CONFORMITY..... 13
Kentmaster Worldwide Location 14
INDEX..... 15
FIGURES - INDEX..... 15

FIGURES - INDEX

Figure 1 BLADE REMOVAL..... 3
 Figure 2 6303000: MODEL TURBO-III-A..... 5
 Figure 3 BOM FOR MODEL TURBO-III-A..... 6
 Figure 4 ECCENTRIC SHAFT ASSAMBLY 7
 Figure 5 AIR MOTOR & PINION ASSEMBLY 8
 Figure 6 6302630: VALVE ASSEMBLY 9
 Figure 7 MAINTENANCE TOOLS 10