



SANI-MATIC®

Clean-In-Place (CIP) Systems: Consistent, Sanitary Cleaning of Process Lines, Tanks and Vessels.

**One-Tank
Single-Use**



**Multi-Tank
Detergent and Rinse
Recovery/Reuse**



Sani-Matic Clean-In-Place (CIP) Systems are engineered to your specific plant application and utility requirements for effective and efficient process equipment cleaning. Proper CIP design and sizing ensure sufficient flow and appropriate pressure to thoroughly remove residue, rinse effectively, shorten cycle times, reduce operating costs and promote worker safety. The Sani-Matic CIP Systems are sanitary and can be engineered to 3-A guidelines.



Sani-Matic Clean-In-Place (CIP) Systems can be portable or stationary, single-tank, two-tank, or multi-tank, single-use, re-use, or once-through, as well as designed for multi-circuit capabilities.

Advantages

- **Programming & Controls.** Sani-Matic controls are designed to optimize cycle times and reduce chemical and water use. Ethernet communications interface with individual process control systems for an integrated solution.
- **Craftsmanship.** Sani-Matic craftsmen have decades of experience constructing sanitary systems and weld to AWS D18 standards.
- **Documentation.** Complete documentation to comply with regulatory and customer standards is available, as is the SaniTrend data acquisition and management system.
- **Services.** Sani-Matic's dedicated service team provides full technical support during the start-up and after installation.

Features

One-Tank Single-Use

- Single-use source of cleaning solution and rinse water
- Lower capital investment
- Portable or stationary design
- Once-through or recirculated
- Simple and flexible operation
- Lower space requirement



Two-Tank Detergent Recovery/Reuse

- Permits recovery and reuse of wash solution
- Used where water utilities are limited
- Supply/recirculation option
- Decreases wash cycle time

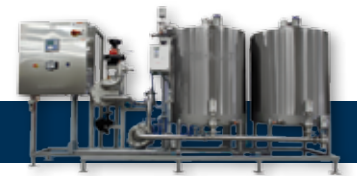

One-Tank Schematic

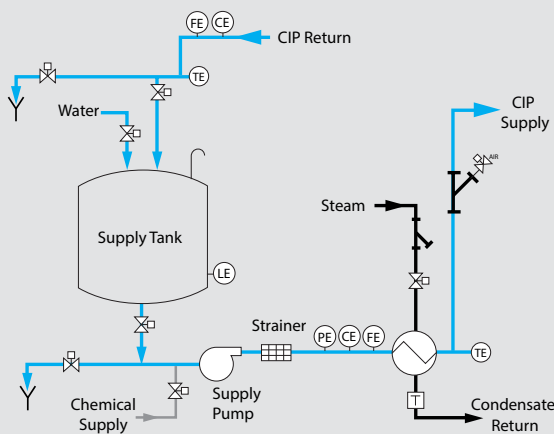

Two-Tank Schematic

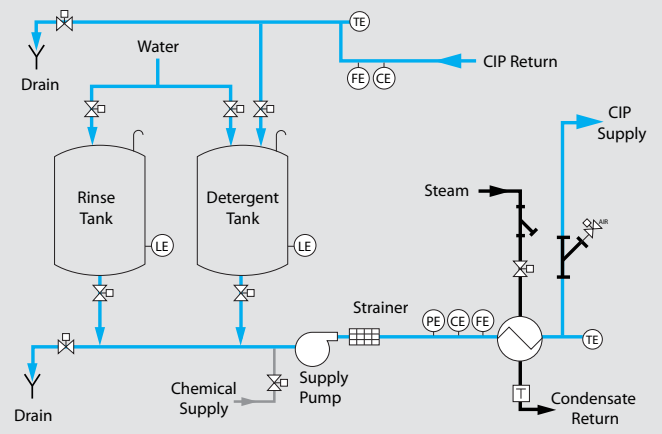

Controls

Sani-Matic has designed, manufactured and supported thousands of CIP control systems with its in-house programmers and UL authorized panel shop.

Advantages of Sani-Matic Controls

- **Experts.** The Sani-Matic programming and automation team specializes in cleaning applications and provides proven expertise and customized strategies.
- **Automation Ease & Flexibility.** Easy-to-understand Recipe Editor provides access to setpoints. Defined alarms reduce troubleshooting time.
- **Water & Chemical Savings.** Recipe optimization shortens cycle time and minimizes water and chemical use.

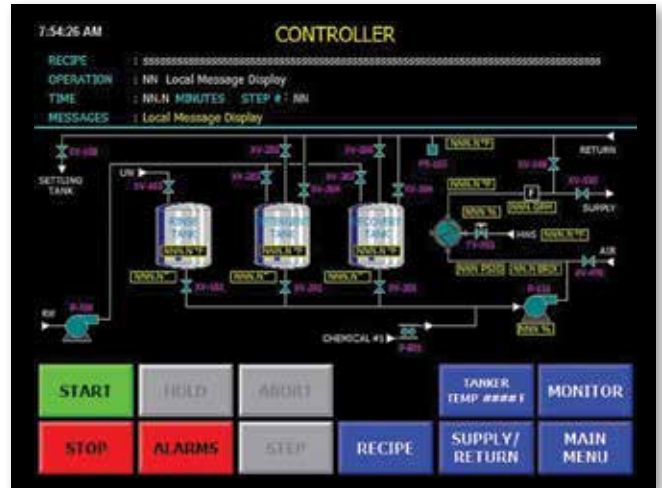

We mix our industry-specific expertise with the perfect combination of Time, Action, Chemical and Temperature to deliver the best solution for your cleaning challenge.



Features

Multi-Tank Detergent and Rinse Recovery/Reuse

- Permits recovery and reuse of wash solution and rinse water
- Reduces water and waste water costs
- Fourth tank may be added for acid recovery and reuse applications (shown in photo above)

Multi-Circuit and Recovery/Reuse

- Serves multiple circuits independently and simultaneously
- Substantial cost and space-saving advantages over multiple separate units
- Centralized controls
- Reduced wash and rinse cycle times

Multi-Tank Schematic

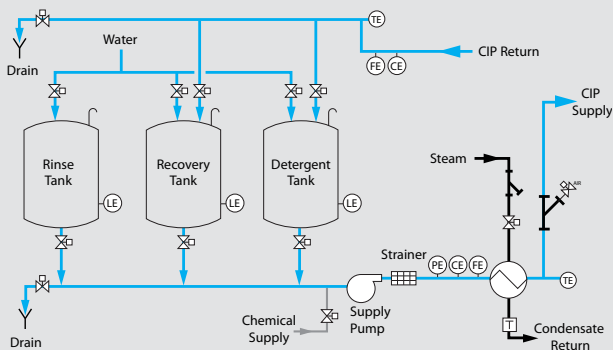

Multi-Circuit Schematic (Dual Operating)

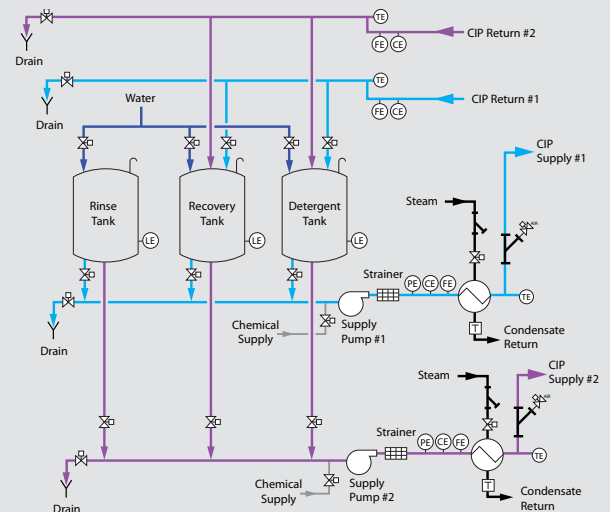

Cleaning Confidence.

Repeatable results you can count on every time you clean your process parts and equipment.
That's Cleaning Confidence from Sani-Matic.



SANI-MATIC

sanimatic.com

