



FLOWAY

For order picking shelves and roller carpets

Product Description

- Supports the lateral profile flanges on the shaft
 - Guarantees the free-running of the wheels even under heavy loads
- Wheel tracks for order picking shelves
- Roller carpets for gravity and pushing operations
- For lightweight and medium-heavy materials to be conveyed
- For inclined conveyors and pushing operations
- Wheels made of highly compressed polyethylene
- Zinc-plated steel profile
- Continuous, zinc-plated, 3 mm shaft

Technical Data

General technical data

Material	Polyamide
Standard pitch	28 mm
Roller colour	Black
Max. load capacity per wheel	80 N

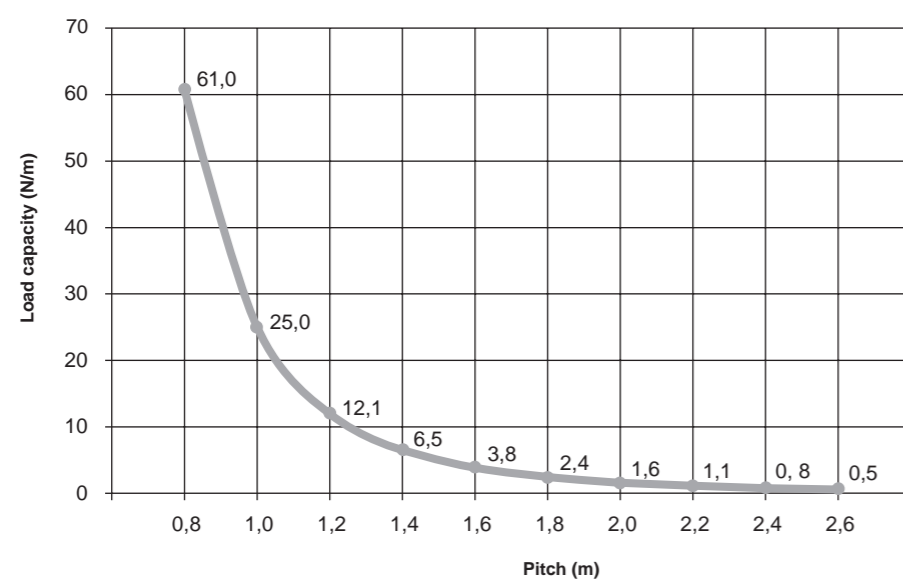

Please clarify the profile length with your Interroll customer consultant.

Dimensions

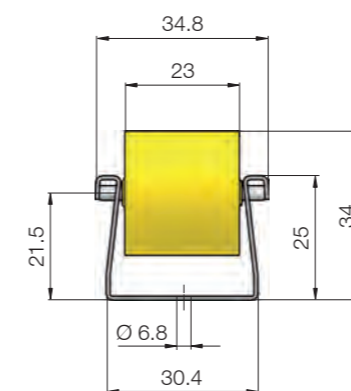

Fig.: Wheel

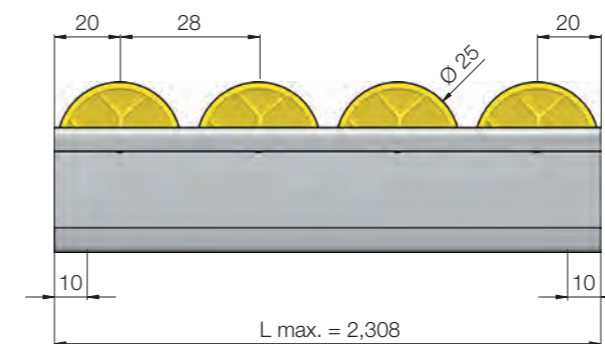

Fig.: Wheel track

Customer
benefits

Applications

Properties

Load capacity

Ordering
information