



HEAVY DUTY FLANGED BRACKET ALUMINIUM

Set of brackets for mounting a drum motor or an idler pulley

Product Description

- Application**
- ✓ For Interroll Drum Motors 80i, 113i, 138i, 165i and corresponding idler pulleys
 - ✓ For drum motors with cable connectors or terminal box
 - ✓ Only for drum motors with a cross drill thread in the front shaft (non cable / terminal box side)
 - ✓ Only for idler pulleys with a threaded hole in each shaft end

Note: For threaded shaft dimensions refer to the dimensional drawings for the respective drum motor.

Mounting Overview

Brackets must be mounted in the following way:

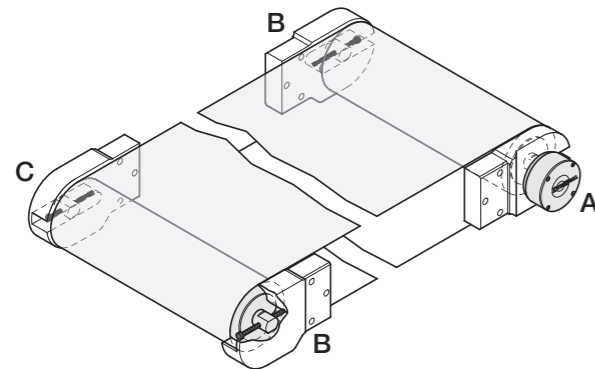

Dimensions

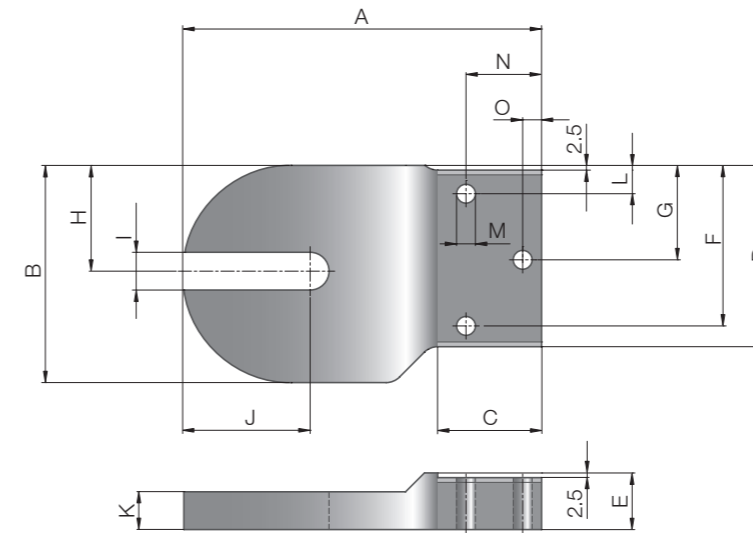

Fig.: Right-hand side bracket (A) for drum motor with elbow connector, straight connector or terminal box

Product Range

Drum Motor	Idler Pulley	Bracket set	Material	Electrical connector	Art. No.
113i		A + B	Aluminium	Elbow connector Straight connector Terminal box	61008698
113i		A + B	Aluminium	Cable slot connector	61008699
138i		A + B	Aluminium	Elbow connector Straight connector Terminal box	61008704
138i		A + B	Aluminium	Cable slot connector	61103900
165i		A + B	Aluminium	Elbow connector Straight connector Terminal box	61008707
165i		A + B	Aluminium	Cable slot connector	61103901
80i		A + B	Aluminium	Elbow connector Straight connector Terminal box	61008694
	80i	B + C	Aluminium		61008696
	113i	B + C	Aluminium		61008701
	138i	B + C	Aluminium		61008706
	165i	B + C	Aluminium		61008708

Note: 165i only with key flat length of 25 mm (must be ordered specially)

Drum Motor	A mm	B mm	C mm	D mm	E mm	F mm	G mm	H mm	I mm	J mm	K mm	L mm	M	N mm	O mm
80i	120.0	85.0	25.0	62.5	20.0	50.0	-	40.0	13.5	47.5	9.0	15.0	M8	10.0	-
113i	190.0	115.0	55.0	96.0	30.0	85.0	50.0	56.0	20.0	67.5	20.0	15.0	M8	40.0	10.0
138i	200.0	140.0	55.0	121.0	30.0	110.0	62.5	67.0	20.0	80.0	20.0	15.0	M10	40.0	10.0
165i	240.0	170.0	55.0	146.0	30.0	122.5	75.0	81.0	30.0	100.0	20.0	27.5	M10	40.0	10.0



HEAVY DUTY FLANGED BRACKET ALUMINIUM

Set of brackets for mounting a drum motor or an idler pulley

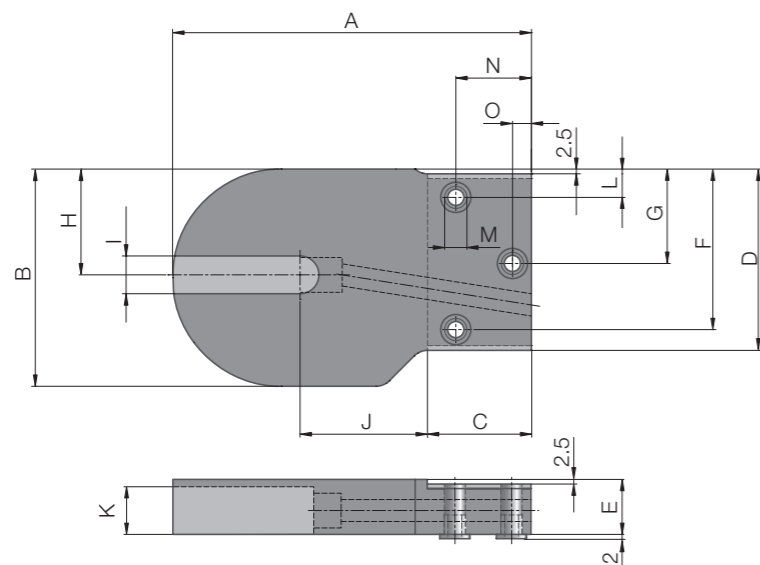

Fig.: Right-hand side bracket (A) for drum motor with cable slot connector

Drum Motor	A mm	B mm	C mm	D mm	E mm	F mm	G mm	H mm	I mm	J mm	K mm	L mm	M	N mm	O mm
113i	190.0	115.0	55.0	96.0	30.0	85.0	50.0	56.0	20.0	67.5	26.0	15.0	M8	40.0	10.0
138i	200.0	140.0	55.0	121.0	30.0	110.0	62.5	67.0	20.0	80.0	26.0	15.0	M10	40.0	10.0
165i	240.0	170.0	55.0	146.0	30.0	122.5	75.0	81.0	30.0	100.0	26.0	27.5	M10	40.0	10.0

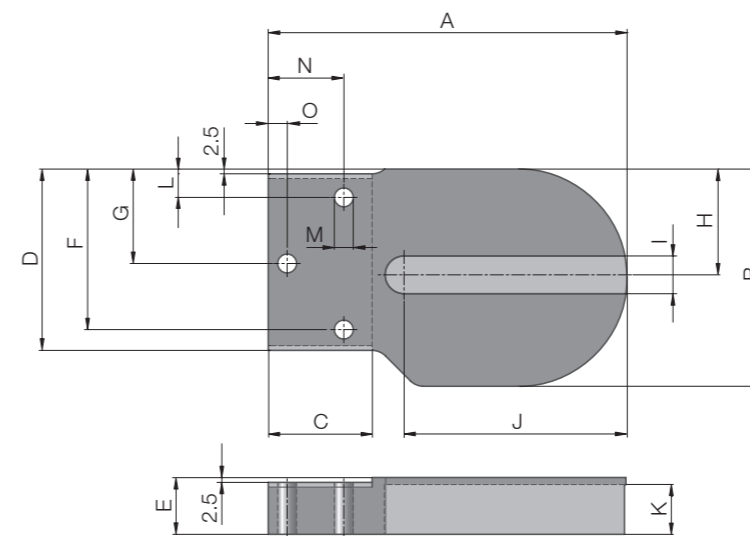

Fig.: Left-hand side bracket (B) for drum motor and idler pulley

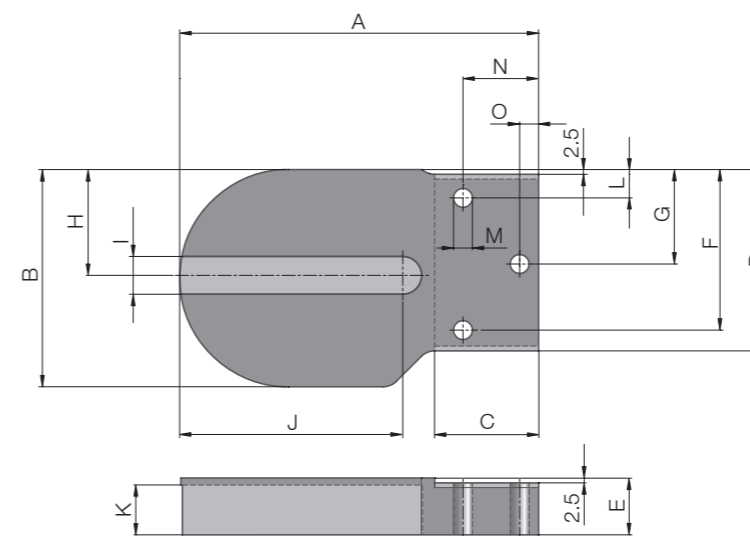

Fig.: Right-hand side bracket (C) for idler pulley

Drum Motor	A mm	B mm	C mm	D mm	E mm	F mm	G mm	H mm	I mm	J mm	K mm	L mm	M	N mm	O mm
80i	120.0	85.0	25.0	62.5	20.0	50.0	-	40.0	13.5	85.0	13.0	15.0	M8	10.0	-
113i	190.0	115.0	55.0	96.0	30.0	85.0	50.0	56.0	20.0	120.0	26.0	15.0	M8	40.0	10.0
138i	200.0	140.0	55.0	121.0	30.0	110.0	62.5	67.0	20.0	130.0	26.0	15.0	M10	40.0	10.0
165i	240.0	170.0	55.0	146.0	30.0	122.5	75.0	81.0	30.0	165.0	26.0	27.5	M10	40.0	10.0