



Boiler Blowdown Heat Recovery Systems - Installation, Operation and Maintenance

General layout

Note: Water supply to cold water make-up tank not shown.

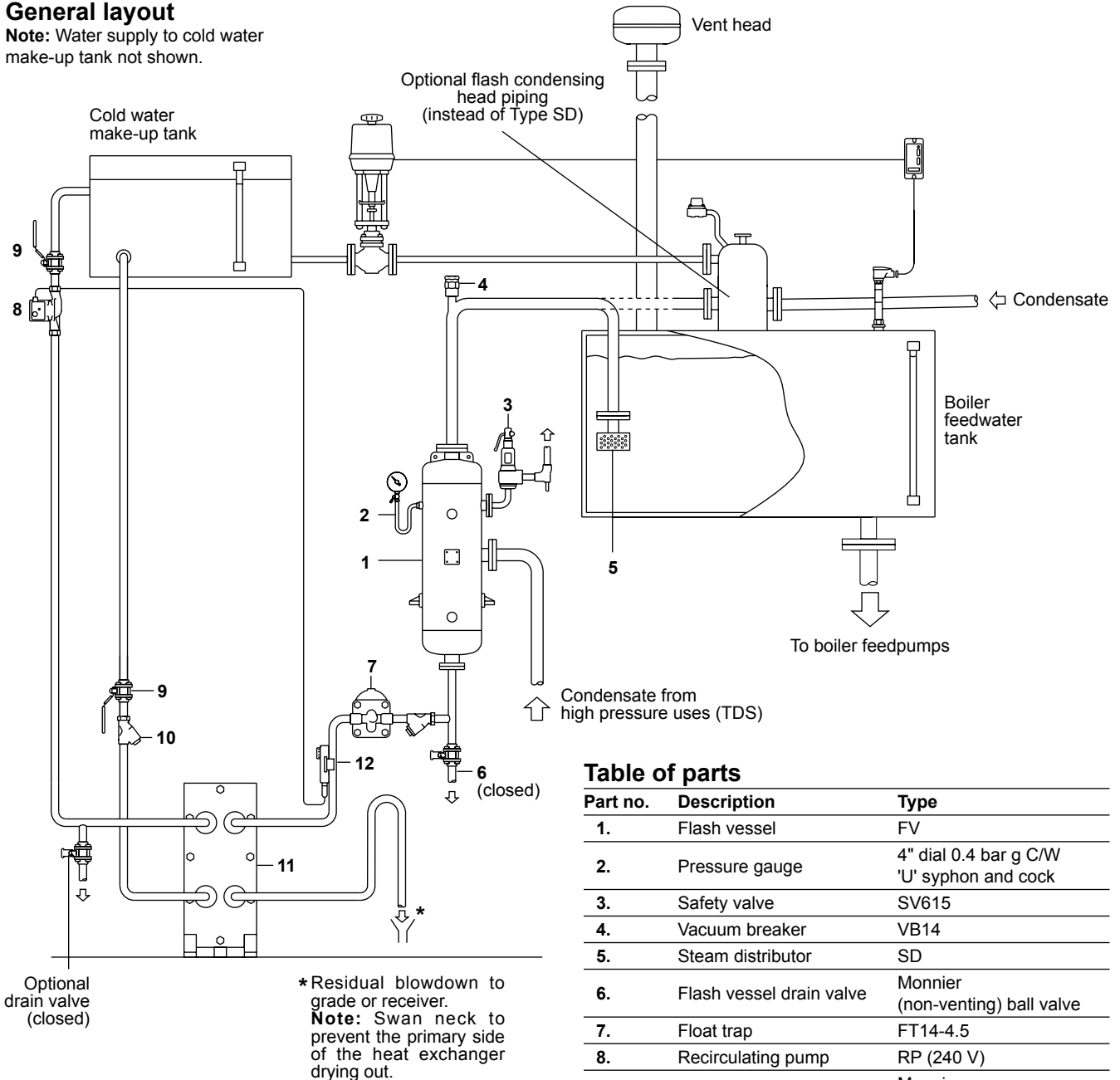

Table of parts

Part no.	Description	Type
1.	Flash vessel	FV
2.	Pressure gauge	4" dial 0.4 bar g C/W 'U' syphon and cock
3.	Safety valve	SV615
4.	Vacuum breaker	VB14
5.	Steam distributor	SD
6.	Flash vessel drain valve	Monnier (non-venting) ball valve
7.	Float trap	FT14-4.5
8.	Recirculating pump	RP (240 V)
9.	Tank isolating valves	Monnier (non-venting) ball valve
10.	Pump strainer	Fig 12 SG iron or Fig 13 cast iron
11.	Plate heat exchanger	Type M3 or M6
12.	Thermostat	Type HTS3

Note: Item 5 can be replaced with a flash condensing head (if present) as shown in the diagram above.

Fig. 1

Safety information

Your attention is drawn to Safety Information sheet IM-GCM-10 as well as to any national or regional regulations concerning boiler blowdown. In the UK guidance is given in HSE Guidance Note PM60.

General information

This information describes the Spirax Sarco heat recovery system which is designed to recover the heat in discharged boiler water from automatic TDS control systems, and a proportion of this water in the form of flash steam. The heat recovery system must only be used to recover heat from the TDS blowdown. There will be another blowdown point on the bottom of the boiler used for the intermittent removal of precipitates. This should be kept entirely separate from the heat recovery system. Refer to separate literature for system selection details. This equipment is designed to save energy. All pipework and the flash vessel should be lagged.

Installation

Flash vessel

As water passes through the blowdown valve it is reduced in pressure. Flash steam is formed and the pipework downstream of the valve will contain a mixture of steam and blowdown water travelling at high velocity. If the pipeline to the flash vessel is too small in diameter the result may be erosion of the pipework with turbulence and carryover as it enters the flash vessel.

The best arrangement is to increase the size of the pipework after the blowdown valve:

- Install the flash vessel at a high level adjacent but not bolted to the feedtank.
- Fit the pressure gauge set, safety valve and vacuum breaker as shown in Figure 2.
- Pipework from the flash vessel to the feedtank should match the vessel's vent size.
- The safety valve should always be fitted with the centreline of the spring housing vertically above the valve.
- The discharge pipework must be installed so that undue stresses are not imposed upon the safety valve that could cause distortion and leakage.
- Discharge pipework should be as short and straight as possible and discharge where it can not cause damage or injury to property or persons. Discharge pipework must not be smaller in diameter than the valve outlet. Where it is necessary to install discharge pipework over a long distance lowering of the performance and possible chatter can be avoided by fitting larger diameter pipe.
- There must be no shut-off device on the inlet or outlet of the safety valve.
- The size of pipework to drain should match the flash vessel drain connection size.
- The vacuum breaker must be installed in a vertical position above the flash vessel in the flash steam line to prevent a vacuum forming when the blowdown valve shuts off.

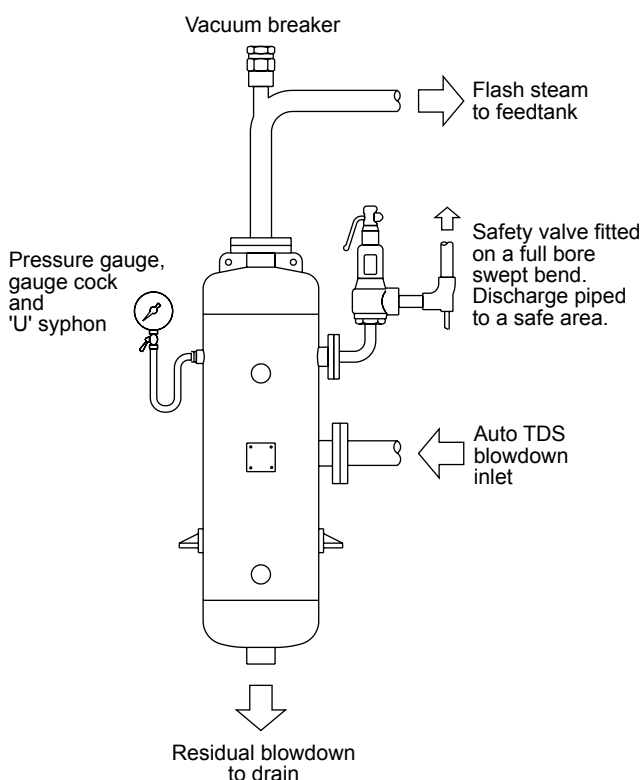

Fig. 2 Flash vessel

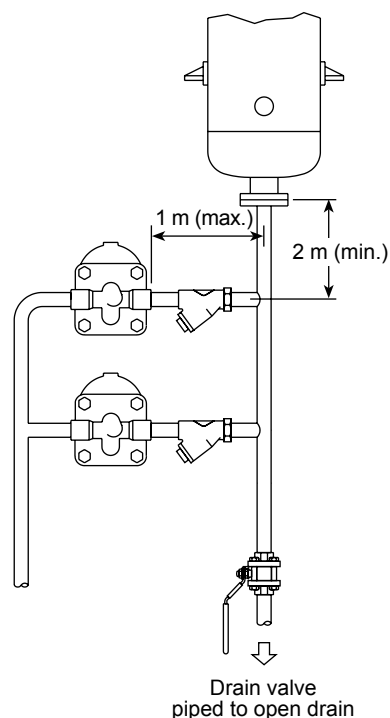

Fig. 3 Example showing two float traps in parallel when capacity demands

Float trap

The build up of water in the flash vessel must be avoided so a float trap with continuous drainage of condensate at saturation temperature is essential. The trap must be fitted so that the float arm rises and falls vertically with the direction of flow as indicated on the body. Where capacity demands two float traps should be fitted in parallel (see Figure 3). The flowrate of residual blowdown through the trap is dependent on the head of water above it. For the full rated capacity of the system the trap should be positioned at least 2 m below the flash vessel as shown in Figure 3. It is usually most convenient to fit the trap at a low level for easy access immediately above the heat exchanger. No more than 1 m of horizontal pipework should be used between the flash vessel and the float trap inlet to prevent the float trap from becoming steam locked.

Heat exchanger (see Figure 4)

All piping to and from the plate heat exchanger and shut-off valves should match the connection size of the exchanger. Pipes should be fitted so that any thermal expansion does not affect the plate heat exchanger or the fittings. This may be accomplished inherently within the piping or by flexible connections. Valves and piping are to be mounted without tension on the heat exchanger connections.

We recommend that the residual blowdown being discharged to drain is visible to provide a means of checking that the system is operating correctly. Use a swan neck to ensure the primary side of the heat exchanger is always full of water. This prevents problems caused by sludge, and damage to gaskets.

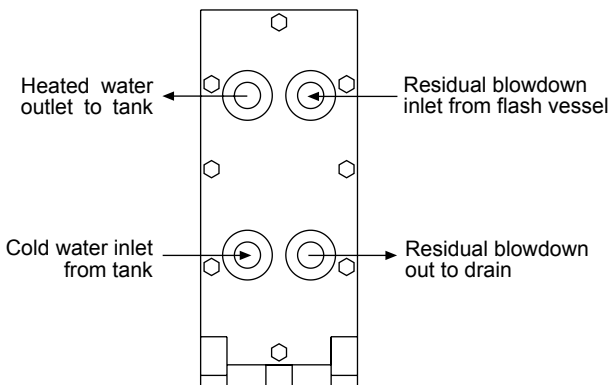

Fig. 4 Heat exchanger - Piping

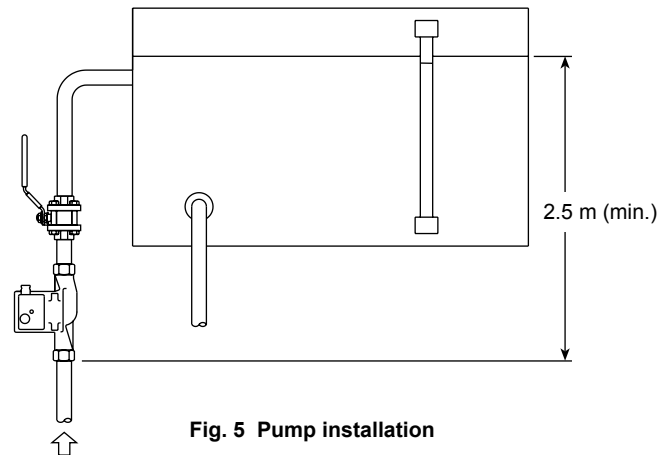

Fig. 5 Pump installation

Pump

The pump should be situated in a vertical pipe pumping upwards as shown in Figure 5. This position ensures that the pump shaft is horizontal which reduces the thrust bearing load and ensures positive air purging from both the rotor chamber and impeller housing. Where pumps can only be installed in horizontal pipework, it is imperative that the pump shaft is horizontal, or slightly higher at the vent plug end. The shaft must not fall below the horizontal plane, even by a few degrees, as this causes premature wear of the top bearing and shaft. Pumps are not to be installed with the shaft in the vertical plane, as this may lead to dry running of the top bearing, noise and possible pump failure. Try to position the pump motor away from hot surfaces and allow access to the switch on the terminal box. Ensure that the pump is not stressed by the pipework and that the pipework is properly supported either side of the pump. If necessary use proprietary mounting brackets. Pipework downstream of the pump is to match the outlet connection of the pump including the isolating valve.

Arrows on the pump base indicate the water flow direction through the pump. When connecting the pump to pipework, the gasket and union nut should be assembled dry:

- It is not necessary to use any sealants.
- Ensure that the gasket is positioned correctly and tighten the union nut firmly. Do not over tighten and take care not to displace or distort the gasket.
- The pump should not be subjected to extremes of temperature. Do not attempt to start the pump until the system has been filled with water and both the pump and system have been vented. To avoid any possible sediment do not fit the pump in the lowest part of the system and position the take off point from the cold treated water storage tank above the base of the tank.
- The return line should be below the lowest water level in the storage tank.
- The minimum inlet pressure to avoid cavitation of the pump is equivalent to 2.5 m head of water. It is recommended therefore that the pump is installed at least 2.5 m below the lowest water level of the cold treated water storage tank as shown in Figure 5.

Thermostat

The HTS3 thermostat should be installed on the pipework leading from the flash vessel drain to the heat exchanger inlet, near to the heat exchanger, allowing easy access to the setting arrow. The base of the HTS3 should be held in good contact with the metal of the pipe removing insulation as required. The plastic covered spring fixing cable should be cut to an unstretched length slightly less than the circumference of the pipe and the hook and eyelet screwed into the ends. Stretch the cable round the pipe and position it in the groove across the front of the HTS3. Engage the hook and eyelet.

Electrical connection

Pump

Contactors overload protection is not required for these pumps. A 3 amp fuse must be fitted in conjunction with a proprietary switch capable of disconnecting the electricity supply to the motor:

- The cable size to be used is 3-core, 0.75 mm².
- The cable should be capable of withstanding a minimum temperature of 80°C.
- Remove the terminal box screw and cover.
- Thread the cable through the gland and connect as indicated in the wiring diagram.
- Tighten the cable gland to ensure that the cable is gripped securely.
- Replace the terminal box cover and fasten securely.

WARNING : This pump must be earthed.

HTS3

Run sufficient 3-core electrical connecting cable to reach the HTS3 installation position without being under tension.

- Remove the HTS3 cover by undoing the central retaining screw and connect the cable as shown in Figure 6, HTS3 Wiring diagram.
- Replace and secure the cover.
- The HTS3 is double insulated and no earth connection is required.

WARNING : Disconnect mains supply before removing the cover.

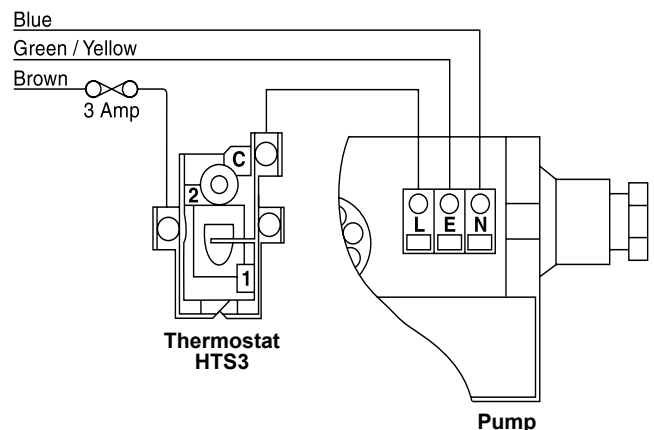

Fig. 6 HTS3 Wiring diagram - When hot 2 and C make contact

Commissioning

General

Following the installation and wiring of the blowdown heat recovery system and prior to refilling the cold treated water storage tank as required all isolating valves should be closed.

- Ensure that the auto TDS system is isolated from the flash vessel until commissioning of the recovery system is complete.
- Turn the dial of the HTS3 clockwise to read an arbitrary figure and ensure that the voltage supply to the pump is off.
- Never run the pump whilst the system is dry or before the pump has been vented.

Heat exchanger

Confirm that the plate pack length is correct, see the table below:

Heat exchanger type	Plate pack length (mm)
M3-8	23
M3-10	29
M3-21	61
M3-31	90
M6-12	30
M6-15	38
M6-19	48
M6-21	53
M6-25	63
M6-33	83

Fig. 7

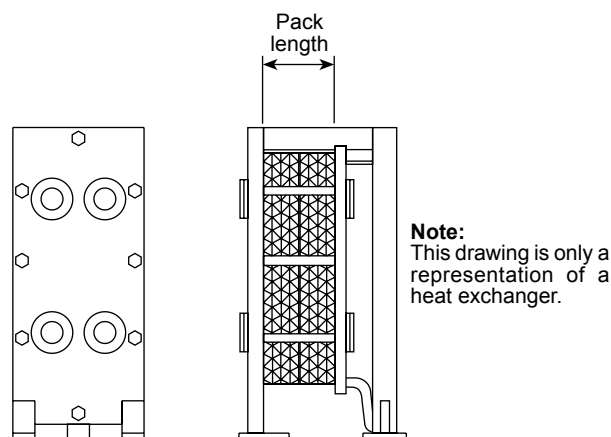

Gradually open the isolating valve leading from the cold treated water storage tank to the heat exchanger inlet. Static pressure must be increased slowly to spare the gaskets any undue stress. Open the isolating valve downstream of the pump. Open the isolating valve on the remaining heat exchanger inlet.

Pump / HTS3

Close the isolating valves either side of the pump i.e. on the pump outlet and on the heat exchanger inlet:

- Slacken the vent plug and remove carefully. Normally the amount of water escaping will be minimal. Take care that water does not enter the terminal box.
- Insert a small screwdriver into the slot in the shaft end and rotate several times to ensure that the shaft is free to move.
- Replace the vent plug but do not tighten.
- Open the isolating valves either side of the pump as previously described. Switch on the power supply to the system. Using a screwdriver turn the setting arrow of the HTS3 fully anti-clockwise. The setting marks outside the temperature scale provide a positive on and off position. Only when fully anti-clockwise should the pump come on.
- When any remaining air has escaped and water only is present tighten the vent plug.
- The pump may be noisy when first switched on due to air remaining in the chamber this should cease after a few minutes running. If noise persists then re-vent.
- Position the HTS3 setting arrow to the desired temperature for switching. 65°C is recommended as a typical setting on this application but if this is not exactly suitable it may be adjusted later. The requirement being that the pump should run whenever there is any useful heat to recover.

WARNING : Do not start the pump until the system has been filled with water and both the pump and system have been vented in accordance with the above instructions.

TDS system

For commissioning of auto TDS systems refer to separate literature. Open up the TDS blowdown to the flash vessel. By blowing down through the auto-TDS system check the operation of the blowdown heat recovery system and adjust the HTS3 switching temperature if required. Observe in particular the operating pressure of the flash vessel that should not exceed 0.5 bar g under normal conditions and that the heat exchanger is working correctly. The temperature of the residual blowdown flowing to drain will be below 40°C in most cases but this depends on the temperature of the water in the cold treated water tank.

Operation

Boiler water at saturation temperature is blown down from the boiler through a valve to the flash vessel. A percentage of this blowdown water will flash to steam as its pressure is reduced typically to 0.2 bar g. The flash steam is allowed to separate in the flash vessel and is then directly introduced into the feedtank through a steam distributor. This increases the temperature within the feedtank thus reducing heating requirements and driving off corrosion-causing dissolved oxygen. Also reduced is the quantity of expensive treated water required to replenish the feedtank. Residual blowdown from the flash vessel flows through a float trap to the heat exchanger where its heat content is used to raise the temperature of water from the cold, treated water storage tank. The circulating pump is thermostatically controlled to ensure that it only runs when the system receives blowdown and there is useful heat to be recovered.

Maintenance

Daily

There are no specific checks to be carried out daily on this system.

Weekly

Take a boiler water sample and check the TDS. Adjust the blowdown controller accordingly. Observe the system under operating conditions for any system faults. Open the flash vessel drain valve whilst there is flow from the TDS system and check that the vessel drain is clear. Operate the isolating valves throughout the system to ensure that they do not seize. Check that the residual blowdown discharge rate increases as the blowdown valve opens. When the valve closes check that the residual blowdown discharged to drain eventually stops.

Annually

Examine the blowdown valve for any damage and replace parts as required. Normally it is not necessary to open a heat exchanger until it is so dirty that its function is impaired. When required open the heat exchanger according to the manufacturers dismantling instructions and clean each plate separately. Cleaning with the plates in the frame is recommended. Clean the plates using a water jet not an abrasive brush. If removed the exchanger plates must be numbered to ensure that they are assembled correctly after cleaning. Inspect the float trap on the flash vessel drain and clear out any deposits checking for any wear of the internals and free movement in all components. Re-commission the system. For the maintenance instructions of TDS systems refer to separate literature.