



Cert. No. LRQ 0963008

ISO 9001

## HL17 High Limit Cut-out

### Description

The HL17 high limit cut-out is a solenoid operated shut-off valve which can be activated by any device capable of interrupting the supply of current to the solenoid coil, such as a thermostat.

### Sizes and pipe connections

DN15, 20, 25, 32, 40, 50 and 80

Screwed BSP (BS 21 parallel) or API (DN15 to 25 only)

Flanges	DN15 - 50 EN 1092 PN16 and PN25
	DN25 - 50 BS 10 Table H and ANSI 300
Also available	DN80 - EN 1092 PN40 and ANSI 300
	DN15 - 50 JIS 10/16 and ANSI 150
	DN15 - 20 BS 10 Table F
	DN15 - ANSI 300
	DN80 - JIS 20, BS 10 Table J and ANSI 150

### Limiting conditions

Body design conditions	DN15 - 50	PN25
	DN80	PN40
Maximum design temperature	190°C	
Maximum operating pressure	10 bar g	
Designed for a maximum cold hydraulic test pressure of:	DN15 - 50	38 bar g
	DN80	60 bar g

### Operating range

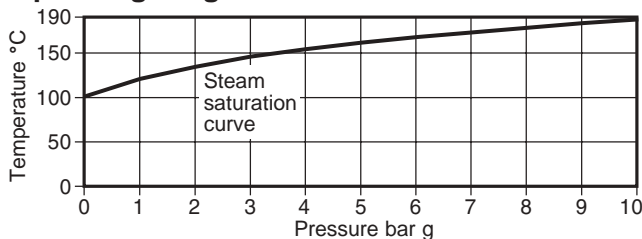

### Technical data (Solenoid valve)

Voltagages available	220/240 ±10% Vac or 110/120 ±10% Vac (others available on request).	
Frequency	50/60 Hz	
Power consumption	Inrush	45 VA
	Holding	23 VA

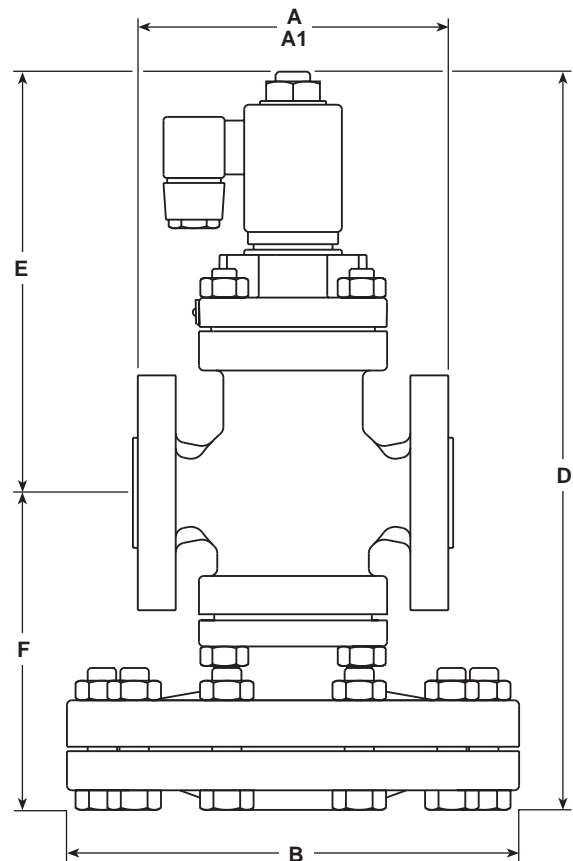

### Capacities

Using the saturated steam sizing chart from TI-GCH-03, establish the required  $K_V$  and then select the next highest valve  $K_V$  from the table below.

DN15	DN20	DN25	DN32	DN40	DN50	DN80
4.0	6.2	9.5	16	22	30	75

For conversion:  $C_V$  (UK) =  $K_V \times 0.963$      $C_V$  (US) =  $K_V \times 1.156$

### Dimensions / weights (approximate) in mm and kg

Size	Screwed A	BS 10 H A1	PN16/25 A1	ANSI 300 A1	BS 10 F A1	ANSI 150 A1	JIS 10/16 A1	B	D	E	F	Weight	
												Screwed	Flanged
DN15	160	-	130	126.6	117	120.2	122	185	301	171	130	11.0	11.8
DN20	160	-	150	-	133	139.4	142	185	301	171	130	11.0	12.7
DN25	180	160	160	160.0	-	160.0	152	207	325	177	148	12.0	15.0
DN32	-	180	180	180.0	-	176.0	176	207	325	177	148	-	16.0
DN40	-	200	200	200.0	-	199.0	196	255	369	191	178	-	28.0
DN50	-	230	230	230.0	-	228.0	222	255	369	191	178	-	30.5
DN80	-	-	PN40 310	319.0	BS 10 J 325	310.0	-	350	473	215	259	-	100.0

## Materials

No.	Part	Material	
1	Body	SG iron	DIN 1693 GGG 40.3
		Steel*	DIN 17245 GSC 25
2	Upper diaphragm chamber	SG iron	DIN 1693 GGG 40.3
		Steel*	DIN 17245 GSC 25
3	Lower diaphragm chamber	SG iron	DIN 1693 GGG 40.3
		Steel*	DIN 17245 GSC 25
4	Body cap	SG iron	
5	Diaphragm plate	Brass	BS 2872 CZ 122
		Stainless steel*	BS 970 431 S29
6	Push rod	Stainless steel	BS 970 431 S29
7	Valve seat	Stainless steel	BS 970 431 S29
8	Valve head	Stainless steel	BS 970 431 S29
9	Return spring	Stainless steel	BS 2056 302 S25
		Stainless steel*	BS 2056 302 S16
10	Lock-nut	Steel	BS 3692 Gr. 8
11	Diaphragms (2)	Phosphor bronze	BS 2870 PB 102 1980
		Stainless steel*	BS 1449 316 S31
19	Gaskets (2)	Stainless steel reinforced exfoliated graphite	
21	Diaphragm chamber bolts	Steel	BS 3692 Gr. 8.8
		Steel*	BS 4882 Gr. 2H
22	Diaphragm chamber nuts	Steel	BS 3692 Gr. 8
		Steel*	BS 3692 Gr. 2H
23	Body bolts	Steel	BS 4439 Gr. 8.8
		Steel*	BS 4439 Gr. B7
24	Body nuts	Steel	BS 3692 Gr. 8
		Steel*	BS 3692 Gr. 2H
30	Solenoid valve	Brass	1.4305
31	Internal strainer	Stainless steel	BS 1449 304 S16

Items marked \* apply to the DN80 valve size only.

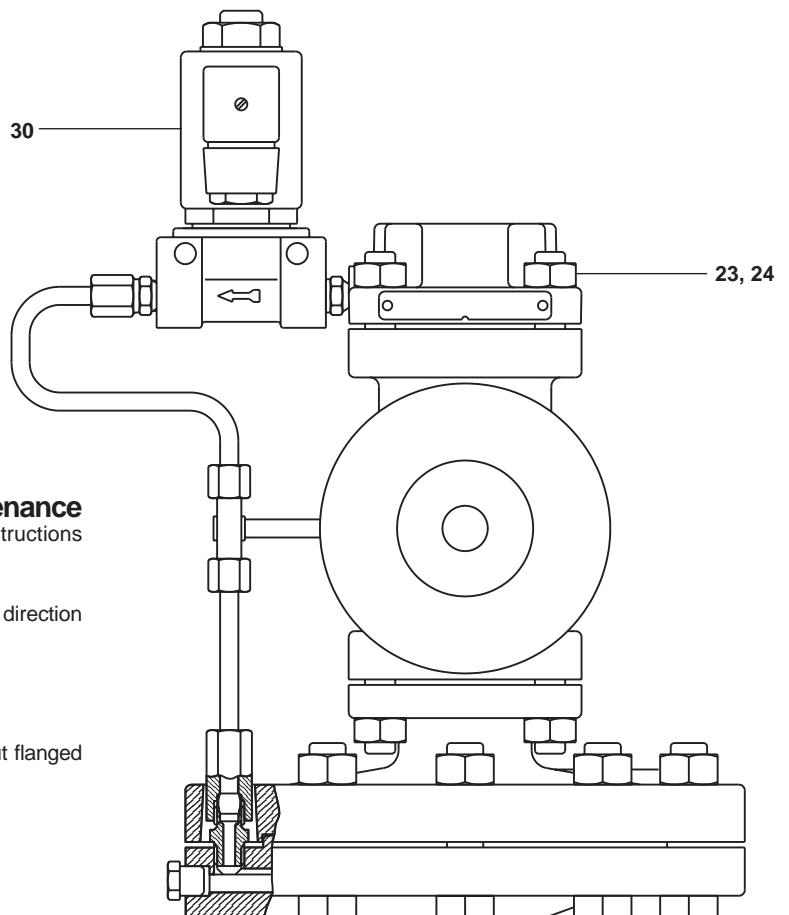
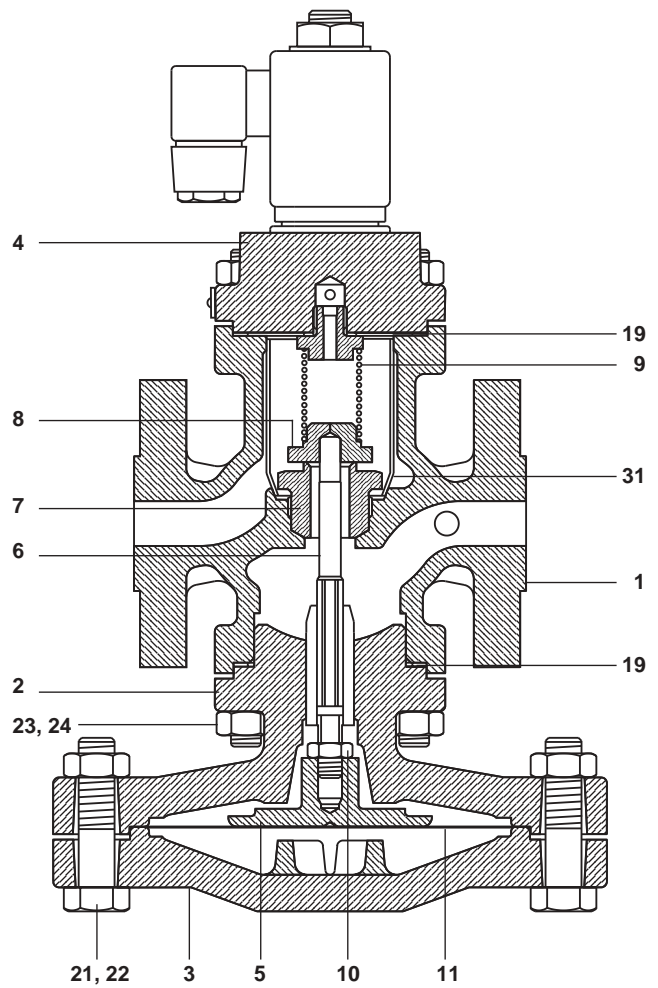

## Safety information, installation and maintenance

For full details see the Installation and Maintenance Instructions (IM-P073-10) supplied with the product.

### Installation note:

The valve should be installed in a horizontal pipeline with the direction of flow as indicated by the arrow on the valve body.

**Spare parts** See IM-P073-10.

### How to order

**Example:** 1 off Spirax Sarco DN32 HL17 high limit cut-out flanged to EN 1092 PN25, fitted with a 110 Vac solenoid.