

MC Temperature Control Systems Types MCO, MC1 & MC2 Installation and Maintenance Instructions

Use

It is important that these control systems are only used with Spirax Sarco valves as indicated in the following table.

| Control System | Range | Valve size and Type |
|----------------|-------------------------------|--------------------------------------|
| MCO | A 55 to 100°C 130 to 210°F | ½" BX or BM |
| | B 88 to 132°C 190 to 270°F | |
| MC1 | A 55 to 110°C 130 to 210°F | ½" to 1" BX, BM, SB, KA, KB |
| | B 88 to 132°C 190 to 270°F | |
| MC2 | A 77 to 138°C 170 to 280°F | ½" to 3" BX, BM, SB KA, KB, NS |
| | | |

Installation

Check the control system supplied is of the temperature range required. It is important that the whole of the temperature sensing area of the sensor is fully immersed in the fluid being controlled as Fig. 1.

Sensors can be held in a screwed nipple by means of a compression ring. Screw the nipple into the boss provided on the plant, thread the union nut and compression ring over the sensor. Insert the sensor fully into the nipple and tighten up the nut and compressing ring. Do not overtighten.

It is likely that the sensor is fitted without a pocket - see note overleaf. Where the sensors are used in conjunction with a pocket, either to allow easy withdrawal or as a protection against corrosion, the separate screwed nipple is dispensed with and the union nut and compression ring attached directly to the top of the pocket. Therefore insert the pocket in place of the screwed nipple.

When using a pocket it is advisable to fill the gap between the pocket and the sensor with a heat conducting medium such as oil.

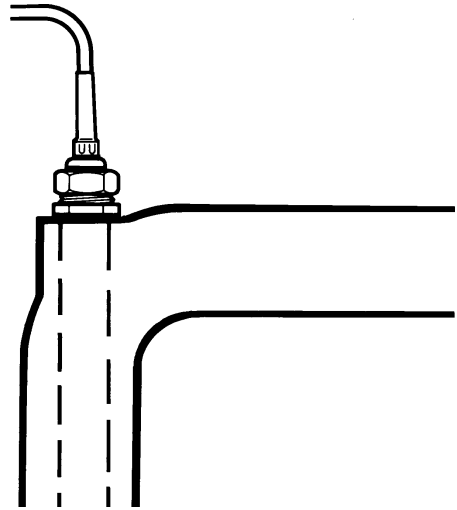

Fig. 1

Where MCO or MC2's are used, these may be despatched with the heater but as a loose item. The remote adjustment head should not be fitted on to the heater, steam or product pipework because of effects of conduction on the control temperature. A mounting bracket is available for the adjustment head and this should be fitted away from hot surfaces.

The Capillary tube between the sensor and the valve must be run and supported in such a way that it will not become damaged. Avoid all sharp bends.

Display Adjustment

The display of the self acting temperature control may be adjusted to suit your specific requirements.

The adjustments include:-

1. Rotation of temperature scale (See Fig. 3).
2. Rotating the dial head (See Fig. 4).



This self acting temperature control is now ready for commissioning as detailed in section commissioning.

Rotating the Scale.

In some instances it may be necessary to rotate the scale so the set temperature may be more easily read. In such cases the following procedure should be adopted and references made to **Figure 2** and **Figure 3**.

1. Remove tamper proof plug (Fig 2, Item 6) and use a suitable screwdriver to set indicator (Fig 2, Item 3) to midway point (Fig 2, Item 1)
2. Remove transparent cover (Fig 2, Item 2)
3. Remove indicator (Fig 2, Item 3)
4. Remove the scale (Fig 2, Item 4) from the indicator and relocate to desired position. (Fig.3)
5. Replace indicator (Fig 2, Item 3) to the midway point of the scale. (Fig 2, Item 1)
6. Replace transparent cover. (Fig 2, Item 2)

This self acting temperature control is now ready for commissioning as detailed in section commissioning

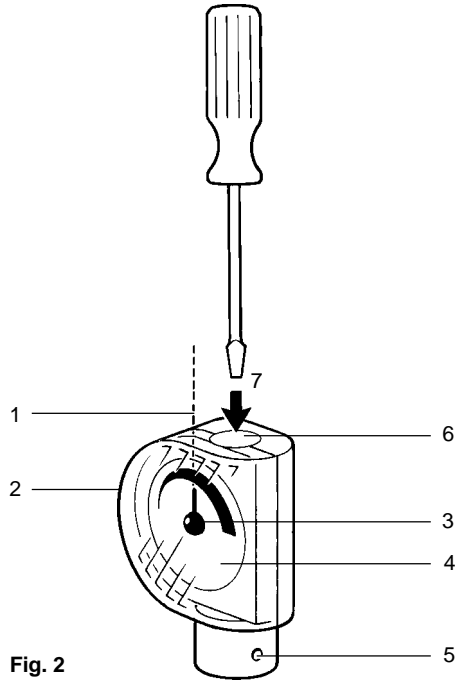

Fig. 2

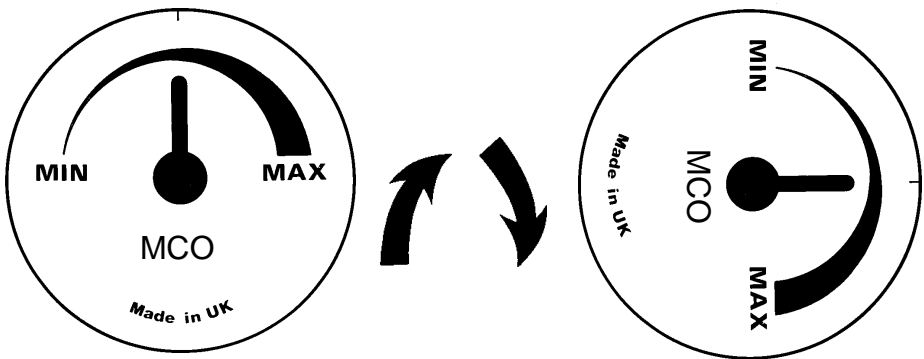

Fig. 3

Rotating the dial head

The dial head itself may be rotated through 180° if necessary. In such cases the following procedure should be adopted and reference made to **Figure 2** and **Figure 4**.

1. Remove tamper proof plug (Fig 2, Item 6) and use a suitable screwdriver to set indicator (Fig 2, Item 3) to midway point (Fig 2, Item 1)
2. Remove transparent cover (Fig 2, Item 2)

3. Remove indicator (Fig 2, Item 3)
 4. Remove dial head retaining screws (Fig 2, Item 5)
 5. Rotate indicator head through 180°.
 6. Replace dial retaining screws. (Fig 2, Item 5)
 7. Replace the indicator to the midway point and replace transparent cover and tamper proof plug.
- This self acting temperature control is now ready for commissioning as detailed in section commissioning.

Commissioning.

For the following instructions you should make reference to Figure 2. The sensor is despatched with its adjustment set to the highest limit and should be set on site to the midway mark (Fig 2, Item 1).

To make any adjustments to suit individual requirements a suitably sized screwdriver is engaged in the adjustment drive (Fig 2, Item 7) on the end of the indicator dial. Turning clockwise will lower the temperature, anticlockwise will increase it. After setting the plant to work, compare the thermometer reading with the scale reading on the temperature control reading. This may be found to differ by a few degrees, if precise control is required it can be adjusted by resetting the scale as follows:-

1. Remove the transparent front cover (Fig 2, Item 2) of the indicator head and turn the indicator manually (Fig 2, Item 3) until it corresponds to the actual temperature.
2. Replace transparent cover (Fig 2 Item 2)
3. Reset the set temperature to the desired temperature.
4. Replace transparent cover and tamper proof plug.

Maintenance

The control system is an entirely sealed unit and requires no maintenance. If damaged or if through fair wear and tear it fails to operate satisfactorily, it can be returned to our works for overhaul.

Warning

On installation where the sensor is immersed directly into the solution to which temperature control is required, we would not recommend the unit to be subjected to:- Aqueous solutions containing chloride, fluoride and halogen. The above applies to complete immersion liquid level lines and splash zones.

Note

Before removing the sensor establish if a pocket is provided by examining the faces of the hexagon head. If these are flat then no pocket is fitted and it will be necessary to isolate/drain the oil line and take the usual precautions when removing the sensor.

If anyone of the hexagon faces is slotted then a pocket is fitted and the sensor can simply be removed.

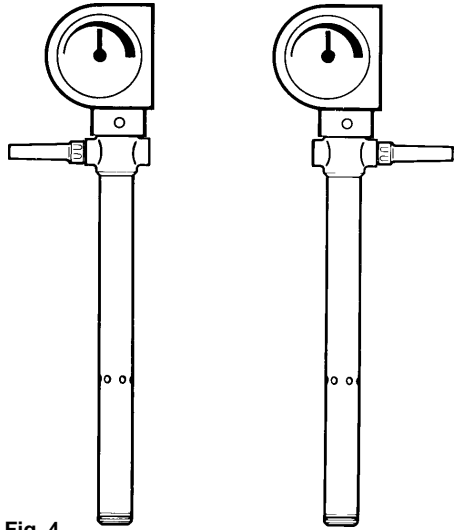

Fig. 4

Valve Types BM, BX, SB, KA, KB & NS Installation

The valve should be fitted in a horizontal pipeline with the actuator vertically below. See Fig. 5. Where space does not permit then the actuator should be vertically above the valve. Other attributes are less satisfactory.

It is important that the line stresses such as can be caused by expansion or inadequate supporting of the pipe are not imposed on the valve body. If the valve is properly sized for the duty it has to perform it will often be smaller than the pipeline to and from it. This is particularly so where the medium passing through the valve is steam, in which case any reduction in line size should be made using eccentric reducers. The piping on both upstream and downstream sides of the valve must be of ample size to avoid undue pressure drop in the line and any reduction to meet the size of the valve should be made close to the valves as in Fig. 5.

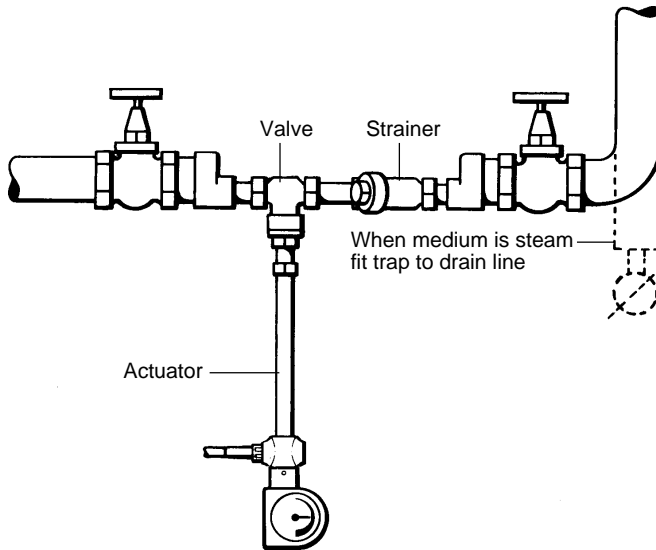

Fig. 5

In most steam installations water formed by condensation due to radiation losses will be present on the upstream pipeline and should be removed by an adequate drain point and trap, as in Fig. 5. It is advisable to protect the valve by fitting a strainer on the upstream side. By fitting the strainer on its side where the medium is steam you will prevent the body filling with water which would reduce the screening area.

Maintenance

The valve faces must be kept clean. The strainer, when fitted should be cleaned at regular intervals to ensure that the flow to the valve is clear and unrestricted.

If at anytime it is necessary to take the valve out of the line for servicing, then before disconnecting the actuator, it is advisable to cool the sensor.

BM, BX, SB, KA & NS Valves

An "Unbrako" screw is provided to allow access for cleaning. For available spares and fitting instructions see :

TI-P036-02 (TIS 1.800)

TI-P044-01 (TIS 1.801)

TI-P036-01 (TIS 1.807)

TI-P049-01 (TIS 1.802)

TI-P078-04 (TIS 1.803)

TI-P078-02 (TIS 1.805)

TI-P078-06 (TIS 1.808)

For copies of these drawings or any other correspondence about these valves, please write to our address.

KB Valves

For available spares and fitting instructions, see drawings TI-P078-04 (TIS 1.803) TI-P078-02 (1.805) TI-P078-06 (TIS 1.808). With bellows assembly it is essential that the central passage

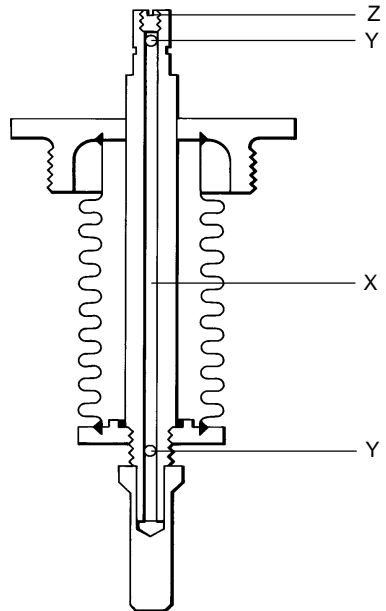

Fig. 6

X through the valve push rod and ports Y are kept clear. To facilitate cleaning, should this become necessary, the end of the passage is blanked by a 4mm 'Unbrako' set screw Z which can be removed to enable a piece of wire to be passed through the passage and ports. It is most important that the set screw is replaced before the valve is put back into service (see Fig 6) For copies of these drawings or any other correspondence about these valves, please write to our address.