

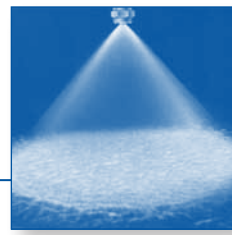

Full cone nozzles
Tangential-flow
Series 422 / 423 Plastic version



Vaneless tangential design combined with PVDF construction offers an excellent nozzle for critical environmental and chemical processing uses.

Applications:

- Mist eliminator washing
- Chemical reactors
- Scrubbers

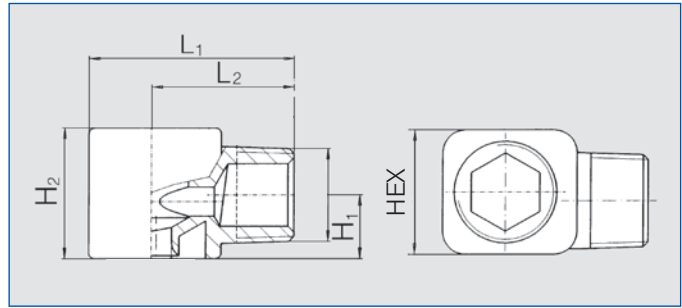
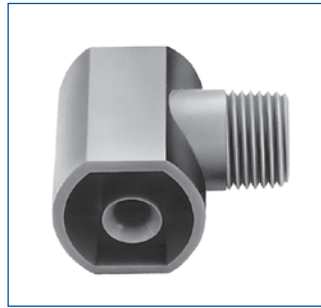

Dimensions (in.)						
Inlet (Male NPT)	L1	L2	H1	H2	Hex	Wt. (lb.)
1/4	1.10	.79	.31	.63	5/8	.02
3/8	1.42	.98	.44	.91	7/8	.04
1/2	1.95	1.32	.76	1.50	1-5/16	.09
3/4	2.30	1.52	.96	1.97	1-5/8	.11

Spray angle	Ordering no.					Orifice diam. (in.)	Free passage (in.)	Flow Rate (Gallons Per Minute)							Spray Diameter D (in.) @ 40 psi		
	Type	Mat. no.	Connection		10 psi			20 psi	liters per minute 2 bar	40 psi	60 psi	80 psi	100 psi	H=8"	H=20"		
			Male NPT 1/4" 3/8"	Male BSPT 1/2" 3/4"													
60°	422. 724	○	-	BE	-	.142	.142	.98	1.4	6.3	2.0	2.4	2.8	3.1	9	20	
90°	422. 406	○	BC	-	-	.059	.057	.16	.22	1.0	.31	.38	.44	.49	15	34	
	422. 486	○	BC	-	-	.075	.071	.25	.35	1.6	.50	.61	.70	.78	15	34	
	422. 566	○	BC	-	-	.091	.087	.39	.55	2.5	.78	.95	1.1	1.2	15	34	
	422. 606	○	-	BE	-	.102	.099	.49	.69	3.2	.98	1.2	1.4	1.6	15	34	
	422. 646	○	-	BE	-	.118	.114	.62	.88	4.0	1.2	1.5	1.8	2.0	15	38	
	422. 726	○	-	BE	-	.146	.142	.98	1.4	6.3	2.0	2.4	2.8	3.1	15	38	
	422. 806	○	-	BE	-	.183	.181	1.6	2.2	10.0	3.1	3.8	4.4	4.9	15	38	
	422. 846	○	-	BE	-	.205	.201	1.9	2.7	12.5	3.9	4.8	5.5	6.1	15	38	
	422. 886	○	-	BE	-	.229	.225	2.5	3.5	16.0	5.0	6.1	7.0	7.9	15	38	
	422. 926	○	-	-	CG	-	.288	.288	3.1	4.4	20	6.2	7.6	8.8	9.8	15	38
	422. 966	○	-	-	CG	-	.315	.315	3.9	5.5	25	7.8	9.5	11.0	12.3	15	38
423. 006	○	-	-	CG	-	.343	.343	4.8	6.8	31	9.6	11.8	13.6	15.2	15	38	
423. 126	○	-	-	-	CK	.473	.473	9.8	13.8	63	19.5	24	28	31	15	38	
120°	422. 408	○	BC	-	-	.059	.057	.16	.22	1.0	.31	.38	.44	.49	27	63	
	422. 448	○	BC	-	-	.065	.063	.19	.26	1.2	.37	.46	.53	.59	27	63	
	422. 488	○	BC	-	-	.075	.071	.25	.35	1.6	.50	.61	.70	.78	27	63	
	422. 568	○	BC	-	-	.091	.087	.39	.55	2.5	.78	.95	1.1	1.2	27	63	
	422. 728	○	-	BE	-	.146	.142	.98	1.4	6.3	2.0	2.4	2.8	3.1	27	63	
	422. 888	○	-	BE	-	.229	.225	2.5	3.5	16.0	5.0	6.1	7.0	7.9	27	63	
	423. 008	○	-	-	CG	-	.343	.343	4.8	6.8	31	9.6	11.8	13.6	15.2	27	63
	423. 128	○	-	-	-	CK	.500	.485	9.8	13.8	63	19.5	24	28	31	27	63

Example Type + Material no. + Conn. = Ordering no.
for ordering: 422. 888 + 5E + BE = 422. 888. 5E. BE

A listing of alternatives for various assembly possibilities is shown in the Accessories section beginning on page 123.

Conversion formula for the above series: $V_2 = V_1 \sqrt{\frac{P_2}{P_1}}$
 (See page 12 for symbol definitions.)



Full cone