



HPHE Heat Pipe Heat Exchanger

Description

Spirax Sarco's Heat Pipe Heat Exchanger (HPHE) range has been designed for horizontal installation in energy recovery applications. These units can be used for heating service with a range of utilities, where hot exhaust gas (otherwise wasted energy) will be provided on the primary side of the unit and water on the secondary side.

These units are manufactured using either two, four or six heat pipe cassettes (4) encased within either one, two or three modules (1). For larger applications where one module will not suffice, either a second or third module can be installed in series, with the main casings being joined together using interconnection flanges - See the 'Side elevation' on page 2 for reference.

Operation

Primary hot exhaust gas travels across the heat pipe cassettes heating the water that flows through them. The heat pipe cassette consists of straight tubes, fastened onto a tube sheet in either rows of four or rows of six depending on the application. The tube sheet maintains an environment whereby no cross contamination can be incurred between the primary hot gas and the secondary fluid. The heat exchanging surface is made of straight smooth or finned tubes that have been specifically designed for use with liquid or gaseous fluids. The HPHE also incorporates a special flange with a plug for adding a venting and blowdown facility to the application.

Design conditions

Primary side

Carbon steel	0.1 bar g @ 500°C
Stainless steel	0.1 bar g @ 650°C

Secondary side

Carbon steel	8 bar g @ 175°C
--------------	-----------------

Available types

To visually appreciate the versatility of the range of units that are available in our standard range, inclusive of the offered optional extras, see the product selection example on page 3.

Standards

The design and manufacturing of the heat pipe cassettes (item 4), that are the central part of the unit, is in accordance with:

- ASME VIII div 1 ed. 2010 code and
- The European Pressure Equipment Directive 97/23/CE.

The HPHE standard series fully complies with the above stated standards and carries the CE mark when so required.

Certification

The HPHE is available with a manufacturer's Typical Test Report.

Note: All certification / inspection requirements must be stated at the time of order placement.

Sizes and pipe connections - See the product selection example on page 3.

Maintenance note: When required the cassettes (4) can be removed for inspection and cleaning

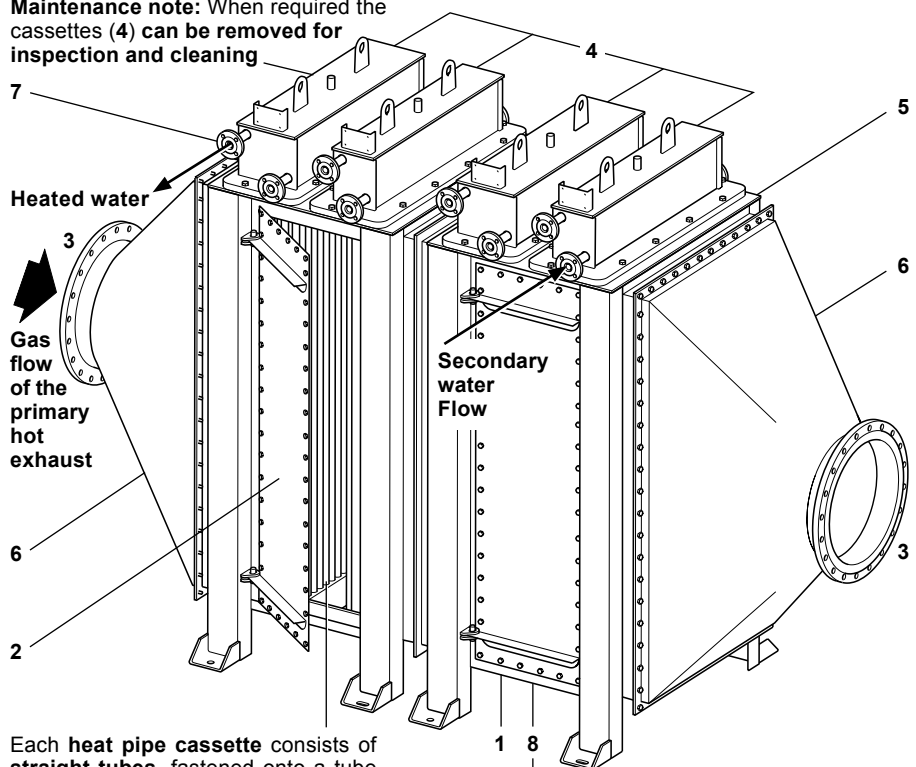

Each heat pipe cassette consists of straight tubes, fastened onto a tube sheet in either rows of four or six deep depending on the application - See the 'Top elevation' on page 2 for clarity.

Please note that the aerodynamic trap (8) is located on the underside of each module (1) - See the 'Side elevation' on page 2 for clarity.

Materials

No.	Part	Material
1	Main casing / Module	Carbon steel or Stainless steel
2	Inspection panel	Carbon steel or Stainless steel
3	Primary side flanges	Carbon steel or Stainless steel
4	Heat pipe cassettes	Carbon steel
5	Tube sheets	Carbon steel
6	Connection pieces	Carbon steel or Stainless steel
7	Secondary side flanges	Carbon steel
8	Aerodynamic trap	Carbon steel or Stainless steel

Dimensions / weights (approximate) in mm and kg

Unit size	Width A	Dimensions				Module	Weights	
		Height B	Length		Cassettes			
			C	D	E		4 tube rows	6 tube rows
Small	S	1070	740	1010	1086	630	560	780
Medium	M	1490	740	1010	1086	710	820	1150
Large	L	1930	740	1010	1254	890	1450	2000

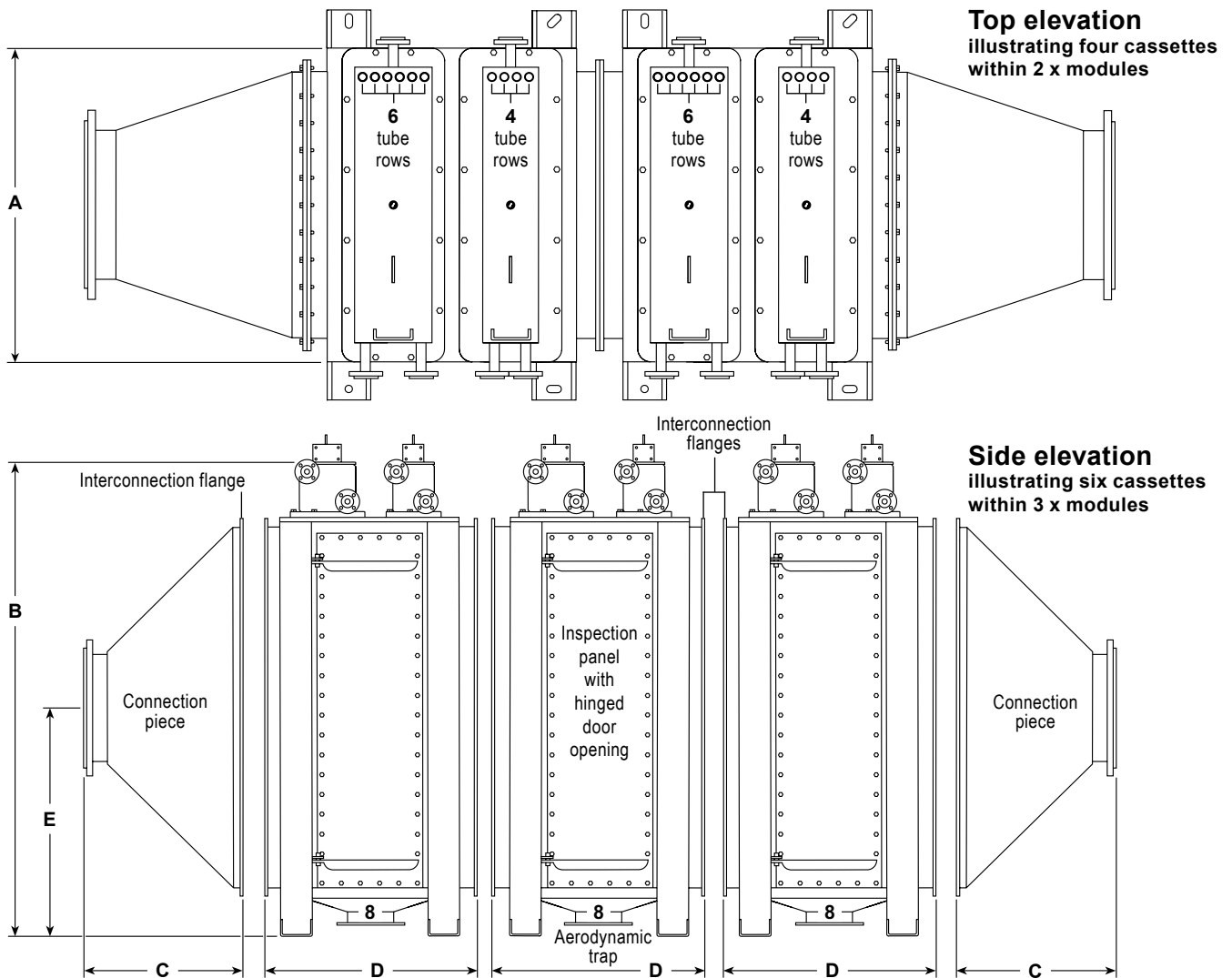

Safety information, installation and maintenance

For full details see the Installation and Maintenance Instructions supplied with the unit.

Installation note:

The HPHE must be installed horizontally.

With very dirty exhaust gas, where fluid contains sediment or suspended particles, the optional aerodynamic trap and a second inspection panel is recommended.

Connected pipework should be installed so that the HPHE connections are not subjected to transmitted loads due to weight or thermal expansion. The heat exchanger should be fixed at one end leaving it free to expand as its temperature rises.

The installation of pressure gauges and thermometers at the inlet and exit of both primary and secondary circuits will allow easy confirmation of correct operation and early detection of cleaning needs.

Maintenance note:

Dependent on the application there is a possibility that a deposit of sediment and fouling will occur. **It is important that a cleaning programme is regularly scheduled** to remove as much of the sediment or suspended particles from the pipework on the primary side of the application. During this period it is recommended that the cassettes are removed for inspection and cleaning. By following these recommendations you will enhance the operation of the unit and maintain optimal performance throughout its life.

Disposal

This product is recyclable. No ecological hazard is anticipated with the disposal of this product, providing due care is taken.

Product sizing and selection

Spirax Sarco has developed integrated thermal modelling, sizing and selection software, to ensure that the HPHE selection operates at its optimum to deliver an efficient application. Further to this the software incorporates a calculator to work out how much energy will be saved, how emissions will be reduced and how much money can be saved by installing a HPHE heating solution from Spirax Sarco.

Please contact Spirax Sarco and talk to one of our highly trained Heat Pipe Specialist and arrange a convenient appointment to ensure the correct heat exchanger is selected to best suit the needs of your plant.

HPHE heat pipe heat exchanger standard series product selection:

Name	HPHE = Heat Pipe Heat Exchanger
Type	GL = Gas to Liquid
Module size	S = Small sized module
	M = Medium sized module
	L = Large sized module
Cassettes	44 = 1 x module: 1 st cassette having 4 x tube rows and the 2 nd cassette having 4 x tube rows
	64 = 1 x module: 1 st cassette having 6 x tube rows and the 2 nd cassette having 4 x tube rows
Pipe type	SS = Smooth / Smooth
	SF = Smooth / Finned
	FF = Finned / Finned
Pipe channel	1 x 1 = 1 pipe per channel
	2 x 1 = 2 pipes per channel
Main casing material of the module	CS = Carbon steel
	SS = Stainless steel
Pipe connections	Primary side = Flanged EN 1092 PN6
	Secondary side = Flanged EN 1092 PN16

Options		
HPHE		
GL		
S		
Module 1	Module 2	Module 3
64	64	
SS		
2 x 1		
CS		
Connections to be flanged: Primary side: EN 1092 PN6 Secondary side: EN 1092 PN16		

Optional extras

Note: If optional extras are required they must be specified at the time of order placement.

The HPHE can be supplied with **inlet and outlet connections of the customers choice.**

An additional **inspection panel and aerodynamic trap.**

Selection example - Please note that the selection example is representative of the illustration in the 'Top elevation' on page 2:

HPHE	GL	S	64 64	SS	2 x 1	CS
-------------	-----------	----------	--------------	-----------	--------------	-----------

The unit must be supplied having the following standard flanged connections:

- Primary side to be flanged EN 1092 PN6
- Secondary side to be flanged EN 1092 PN16.

How to order

Contact your local Spirax Sarco office with your application details and we will supply you with the optimum product solution, inclusive of a quotation to deliver the best performance for your application. Please note that a bespoke design can be provided by Spirax Sarco for larger applications and it is also important to note that packaged solutions incorporating utility supply and controls can also be provided.