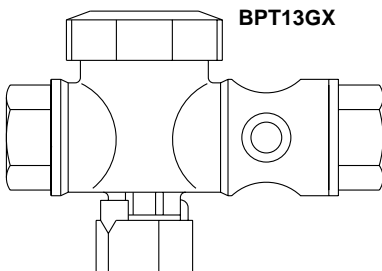
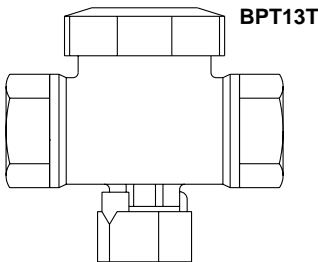

BPT13T and BPT13GX
Balanced Pressure Thermostatic Steam Traps
Installation and Maintenance Instructions

- 1. General safety information*
- 2. General product information*
- 3. Installation*
- 4. Commissioning*
- 5. Operation*
- 6. Maintenance*
- 7. Spare parts*

1. General safety information

Safe operation of the unit can only be guaranteed if it is properly installed, commissioned and maintained by a qualified person (see Section 11 of the attached Supplementary Safety Information) in compliance with the operating instructions. General installation and safety instructions for pipeline and plant construction, as well as the proper use of tools and safety equipment must also be complied with.

Warning:

Under certain conditions corrosive elements in condensate can effect the inside face of the sight tube, particularly where caustic alkali and hydrofluoric acid are present. It is recommended that the sight tube is periodically checked for thinning. If there is evidence of thinning or erosion damage then the sight tube should be replaced immediately. Always wear eye protection when viewing the contents of the sight tube.

Reasonable steps should be taken to protect personnel from injury in the unlikely event that the sight tube breaks.

Isolation

Consider whether closing isolating valves will put any other part of the system or personnel at risk. Dangers might include; isolation of vents and protective devices or alarms. Ensure isolation valves are turned off in a gradual way to avoid system shocks.

Pressure

Before attempting any maintenance consider what is or may have been in the pipeline. Ensure that any pressure is isolated and safely vented to atmospheric pressure before attempting to maintain the product, this is easily achieved by fitting Spirax Sarco depressurisation valves type DV (see separate literature for details). Do not assume that the system is depressurised even when a pressure gauge indicates zero.

Temperature

Allow time for temperature to normalise after isolation to avoid the danger of burns and consider whether protective clothing (including safety glasses) is required.

Viton

If the viton seals have been subjected to a temperature approaching 315°C (599°F) or higher they may have decomposed and formed hydrofluoric acid. Avoid skin contact and inhalation of any fumes as the acid will cause deep skin burns and damage the respiratory system.

PTFE

If seals made from PTFE have been subjected to a temperature approaching 260°C (500°F) or higher, they will give off toxic fumes, which if inhaled are likely to cause temporary discomfort. It is essential for a no smoking rule to be enforced in all areas where PTFE is stored, handled or processed as persons inhaling the fumes from burning tobacco contaminated with PTFE particles can develop 'polymer fume fever'.

Disposal

The product is recyclable. No ecological hazard is anticipated with the disposal of this product providing due care is taken, EXCEPT:

Viton:

- Waste parts can be landfilled, when in compliance with National and Local regulations.
- Waste parts can be incinerated, but a scrubber must be used to remove Hydrogen Fluoride, which is evolved from the product and with compliance to National and Local regulations.
- Is insoluble in aquatic media.

PTFE:

- Waste parts can only be disposed of by approved methods, not incineration.
- Keep PTFE waste in a separate container, do not mix it with other rubbish, and consign it to a landfill site.

2. General product information

2.1 General description

The BPT13T (Fig. 1) is a brass bodied maintainable balanced pressure steam trap with horizontal in-line connections. It has a bypass and stop valve feature built into the trap which simplifies and reduces the cost of installation. The bypass can be used simply to handle high start-up loads or to avoid debris collecting in the steam trap, on the commissioning of new systems.

The BPT13TGX (Fig. 2) has an integral sight tube for indication of operation.

Capsule fill and operation

Note: When placing an order always state capsule fill.

Standard capsules are marked with the letter 'E' for operation at approximately 10°C (18°F) below steam saturation temperature.

Optionally the capsule can be supplied for sub-cooled 'F' operation at approximately 22°C (39.6°F) below steam saturation temperature or a 'G' fill capsule for near-to-steam operation at approximately 4°C (7.2°F) below steam saturation temperature.

Note:

For further information see the following Technical Information Sheet, TI-P126-03, which gives full details of: Materials, sizes and pipe connections, dimensions, weights, operating ranges and capacities.

2.2 Sizes and pipe connections

½", ¾" and 1" screwed BSP.

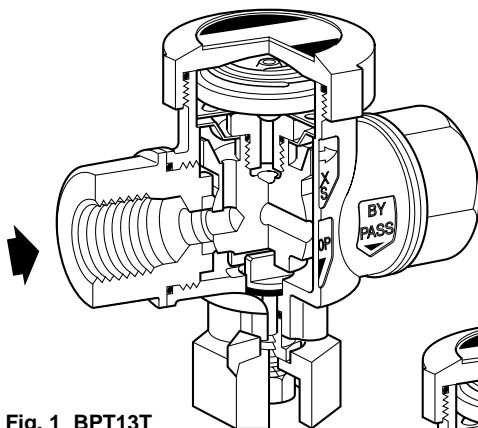

Fig. 1 BPT13T

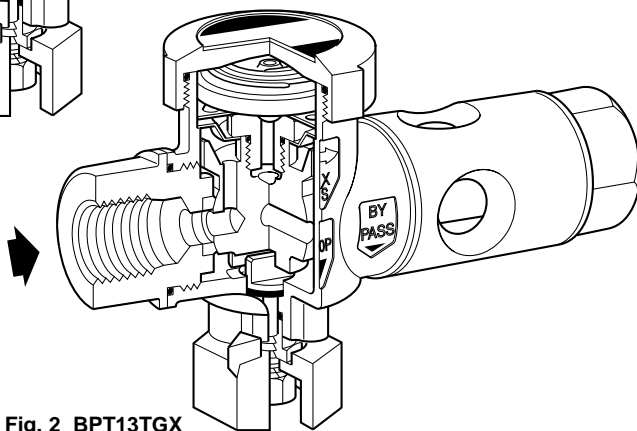
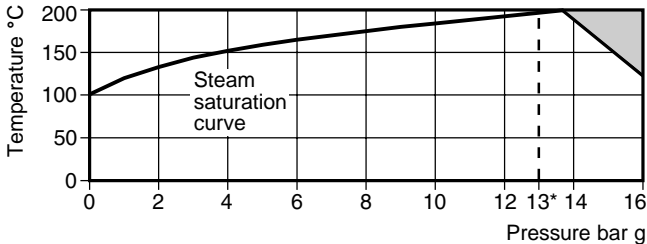



Fig. 2 BPT13TGX

2.3 Limiting conditions

Maximum body design conditions	PN16	
PMA - Maximum allowable pressure	16 bar g	(232 psi g)
TMA - Maximum allowable temperature	200°C	(392°F)
PMO - Maximum operating pressure	13 bar g	(188.5 psi g)
TMO - Maximum operating temperature	200°C	(392°F)
Designed for a maximum cold hydraulic test pressure of:	24 bar g	(348 psi g)

2.4 Operating range



 The product must not be used in this region.

*PMO Maximum operating pressure recommended for saturated steam is 13 bar g (188.5 psi g).

3. Installation

Note: Before actioning any installation observe the 'Safety information' in Section 1.

Warning:

Under certain conditions corrosive elements in condensate can effect the inside face of the sight tube, particularly where caustic alkali and hydrofluoric acid are present. It is recommended that the sight tube is periodically checked for thinning. If there is evidence of thinning or erosion damage then the sight tube should be replaced immediately. Always wear eye protection when viewing the contents of the sight tube.

Reasonable steps should be taken to protect personnel from injury in the unlikely event that the sight tube breaks.

Referring to the Installation and Maintenance Instructions, name-plate and Technical Information Sheet, check that the product is suitable for the intended installation:

- 3.1** Check materials, pressure and temperature and their maximum values. If the maximum operating limit of the product is lower than that of the system in which it is being fitted, ensure that a safety device is included in the system to prevent overpressurisation.
- 3.2** Determine the correct installation situation and the direction of fluid flow.
- 3.3** Remove protective covers from all connections.
- 3.4** The trap is designed for installation with the capsule in a horizontal plane with the cap at the top. Ideally, as with all thermostatic steam traps, a drop/cooling leg should be employed to prevent any cooling condensate from backing up into the steam main.
- 3.5** Isolation valves must be installed to allow for safe maintenance and trap replacement.
- 3.6** Open isolation valves slowly until normal operating conditions are achieved.

3.7 Check for leaks and correct operation.

Note: If the trap is to discharge to atmosphere ensure it is a safe place, the discharging fluid may be at a temperature of 100°C (212°F).

4. Commissioning

After installation or maintenance ensure that the system is fully functional. Carry out tests on any alarms or protective devices.

5. Operation

The operating element is a capsule containing a small quantity of a special liquid with a boiling point below that of water. In the cold conditions that exist at start-up, the capsule is relaxed. The valve is off its seat and is wide open, allowing unrestricted removal of air. This is a feature of all balanced pressure traps and explains why they are well suited to air venting.

As condensate passes through the balanced pressure steam trap, heat is transferred to the liquid in the capsule. The fill liquid boils before steam reaches the trap. The vapour pressure within the capsule causes it to expand and the trap shuts. Heat loss from the trap then cools the water surrounding the capsule, the fill condenses and the capsule contracts, opening the valve and releasing condensate until steam temperature approaches again at which the cycle is repeated.

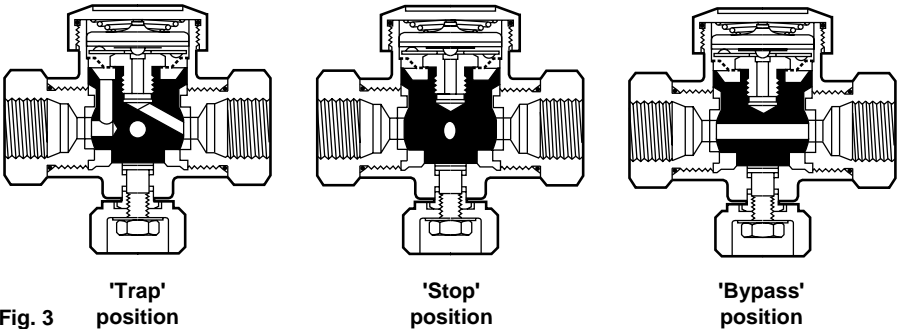

Fig. 3 'Trap' position

'Stop' position

'Bypass' position

Note: The BPT13T is supplied in the 'Bypass' position. To move it to the 'Trap' or 'Stop' position the actuator should be moved until the indicator aligns with the marking on the body (see Fig. 4).

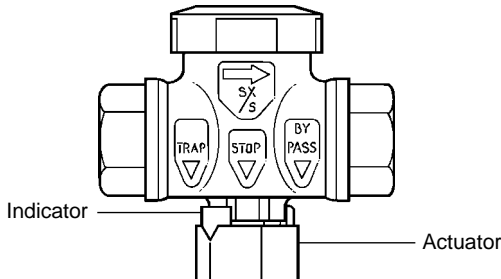

Fig. 4

6. Maintenance

Note: Before actioning any maintenance program observe the 'Safety information' in Section 1.

Warning:

Under certain conditions corrosive elements in condensate can effect the inside face of the sight tube, particularly where caustic alkali and hydrofluoric acid are present. It is recommended that the sight tube is periodically checked for thinning. If there is evidence of thinning or erosion damage then the sight tube should be replaced immediately. Always wear eye protection when viewing the contents of the sight tube.

Reasonable steps should be taken to protect personnel from injury in the unlikely event that the sight tube breaks.

6.1 General information

Before undertaking any maintenance on the trap it must be isolated from the supply line and return line and any pressure allowed to safely normalise to atmosphere. The trap should then be allowed to cool. When reassembling, ensure that all joint faces are clean. Always ensure the correct tools, safety procedures and protective equipment are used at all times.

6.2 Replacement of capsule assembly:

- Isolate the valve and position the trap in the 'bypass' mode.
- Allow the trap to cool.
- Remove the cap (3) and lift out the old capsule (17) , spring (18) and spacer plate (16).
- Unscrew and remove the seat (12) using a small bar through the ball plug (10) whilst it is in the bypass position, to hold it securely.
- At this point the strainer screen (15) can either be replaced or cleaned.
- Replace the seat gasket (11) and screw in a new seat (see Table 1 for recommended torque values), again using a bar to support the ball plug.
- Drop in a new spacer plate (16), capsule (17) and spring (18).
- Screw on the cap (3) using a new 'O' ring (19) assembled into the groove in the top of the cap at torque it up according to the recommended torque values in Table 1.

Note: Always fit a new, complete, capsule assembly when replacing the capsule (see Section 7, Spare parts).

6.3 Other notes for overall refurbishment:

- Care should be taken when unfastening the valve seat (12); put a small bar through the ball plug (10) whilst it is in the bypass position. This is recommended to hold the ball plug securely.
- Retighten the end caps (2) with the actuator (4) in the bypass position when refitting new stem seals (6).
- To avoid incorrectly positioning the ball during reassembly, engagement on the ball plug (10), spindle (5) and actuator (4) is only possible when the ball plug is orientated correctly in the bypass position.
- Ensure the sight tube (22) (BPT13TGX only) is aligned correctly within the housing (20) when tightening the end connection (2). Misalignment may cause the edge of the glass to fracture.

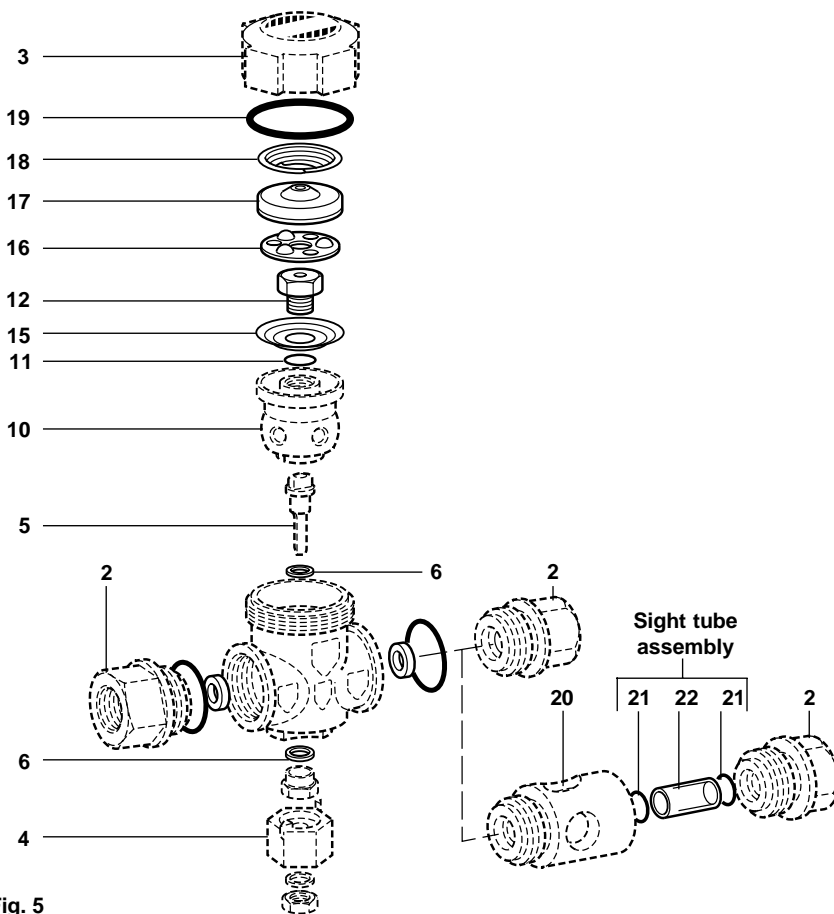



Fig. 5

Table 1 Recommended tightening torques

Item No.	Size	or		N m	(lbf ft)
					
2	DN15	32 A/F		35 - 40	(25 - 29)
	DN20	36 A/F		35 - 40	(25 - 29)
	DN25	46 A/F		35 - 40	(25 - 29)
3	DN15-25	50 A/F		50 - 60	(36 - 43)
4	DN15-25	30 A/F		-	-
7	DN15-25	13 A/F		7 - 10	(5.0 - 7.2)
9	DN15-25	13 A/F		12 - 15	(8.6 - 10.7)
12	DN15-25	17 A/F		12 - 15	(8.6 - 10.7)
20	DN15-25	-		35 - 40	(25 - 29)

7. Spare parts

The spare parts available are shown in heavy outline. Parts drawn in broken line are not supplied as spares.

Available spares

Capsule assembly	16, 17*, 18, 19
Maintenance kit	6 (2 off), 11, 12, 13 (2 off), 14 (2 off), 15, 16, 17*, 18, 19
Sight tube assembly	21 (2 off), 22

***Note:** The capsule can be identified from the letter stamped on the name-plate on the cap (e.g. E, F or G). A standard capsule (E) will be supplied, unless specified otherwise on the order.

How to order spares

Always order spares by using the description given in the column headed 'Available spares' and state the size and type of valve.

Example: 1 - Capsule assembly for a Spirax Sarco BPT13T balanced pressure thermostatic steam trap.

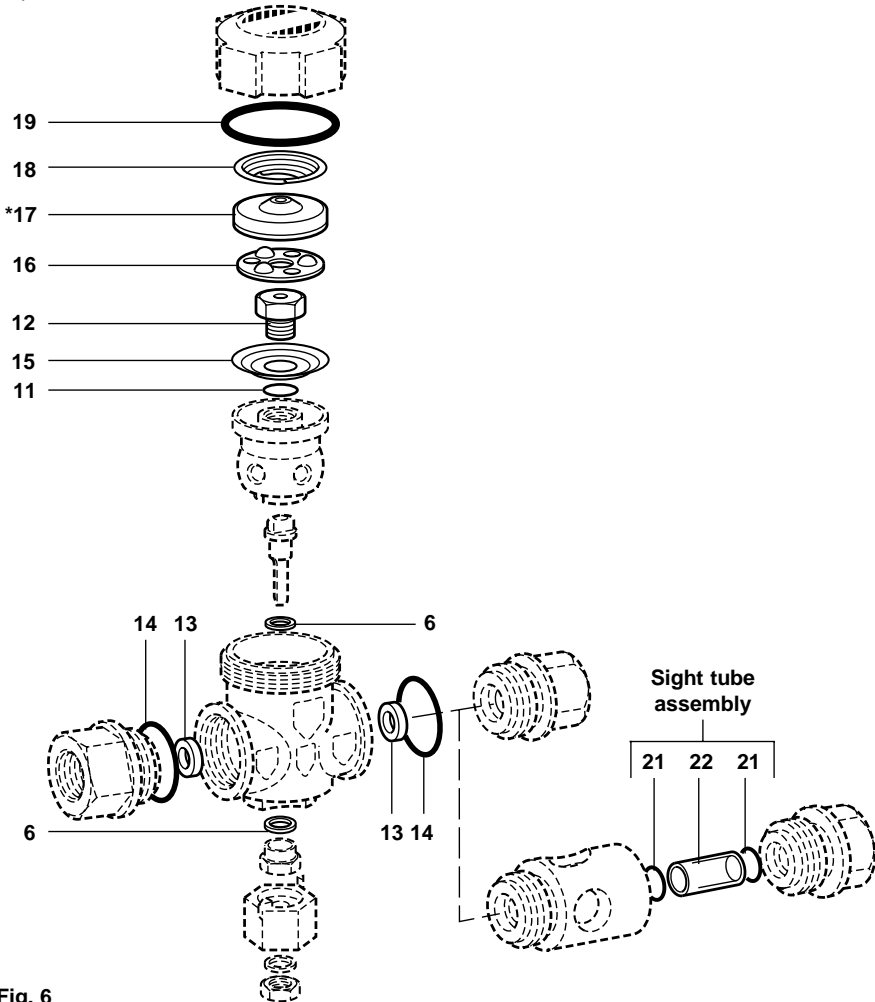

Fig. 6