

spirax sarco

TI-S02-21
 ST Issue 9

FT43 Cast Iron Ball Float Steam Trap DN25 to DN50

Description

The FT43 is a cast iron bodied ball float steam trap having stainless steel working internals and automatic air venting facility. The trap is supplied with integrally flanged connections and can be maintained without disturbing the pipework. Vertical flanged connections, designated FT44V, are available for all sizes. Flow direction for the horizontal trap is clearly illustrated below. For vertically orientated traps the flow is downwards only.

Available options: FT43 – Horizontal flow FT43V – Vertical flow

Capsule

The BP99/32 capsule which is used in the FT43 is suitable for use on 150°C superheat @ 0 bar g and 50°C superheat @ 32 bar g.

Standards

This product fully complies with the requirements of the European Pressure Equipment Directive 97/23/EC and carries the **CE** mark when so required.

Certification

This product is available with a manufacturers' Typical Test Report. **Note:** All certification/inspection requirements must be stated at the time of order placement.

Optional extras

A **manually adjustable needle valve** (designated 'C' on the nomenclature i.e. FT43-C) can be fitted to the FT43. This option provides a **steam lock release (SLR)** feature in addition to the standard air vent. For further information please consult Spirax Sarco.

The **top of the cover can be drilled and tapped 3/8" BSP or NPT** for the purpose of fitting a balance line if requested at the point of order.

The **bottom of the cover can be drilled and tapped 3/8" BSP or NPT** for the purpose of fitting a drain cock if requested at the point of order.

Pressure / temperature limits

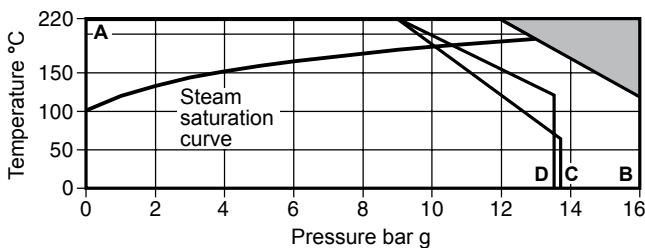

The product **must not** be used in this region.

- A - B Flanged EN 1092 PN16.
- A - C Flanged ASME 125.
- A - D Flanged JIS/KS 10 (DN25 only).

Body design conditions	PN16
PMA Maximum allowable pressure	16 bar g @ 120°C
TMA Maximum allowable temperature	220°C @ 12.1 bar g
Minimum allowable temperature	0°C
PMO Maximum operating pressure for saturated steam service	13 bar g @ 195°C
Note: The DN40 and DN50 traps are limited to a PMO equal to PMX	
TMO Maximum operating temperature	220°C @ 12.1 bar g
Minimum operating temperature	0°C
Note: For lower operating temperatures consult Spirax Sarco	
	FT43-4.5 4.5 bar
ΔPMX Maximum differential pressure	FT43-10 10 bar
	FT43-14 13 bar

Designed for a maximum cold hydraulic test pressure of 24 bar g
Note: With internals fitted, test pressure must not exceed ΔPMX

FT43
 DN25

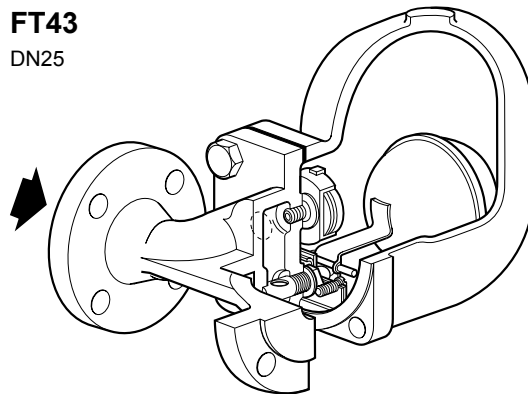

FT43-C

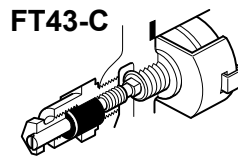

FT43
 DN40 and DN50

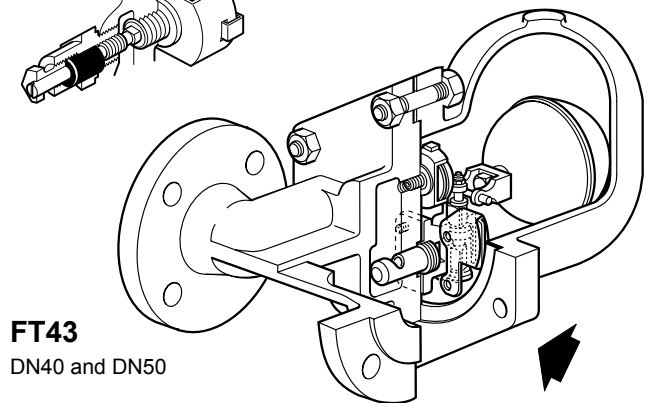

Sizes and pipe connections

DN25, DN40 and DN50

Note: Flow direction, for FT43 horizontal orientated traps, when facing the body: - DN25 is left to right. - DN40 and DN50 is right to left. Flow direction, for FT43V vertically orientated traps is downwards only.

Standard flanges are EN 1092 PN16 with face-to-face dimensions in accordance with EN 26554 (Series 1).

On request - ASME B 16.5 Class 125 and JIS/KS 10 flanges are also available.

Note: ASME flanges are supplied with tapped holes to receive flange bolts. JIS/KS flanges will be supplied drilled as normal with plain bolts holes.

FT43
DN25

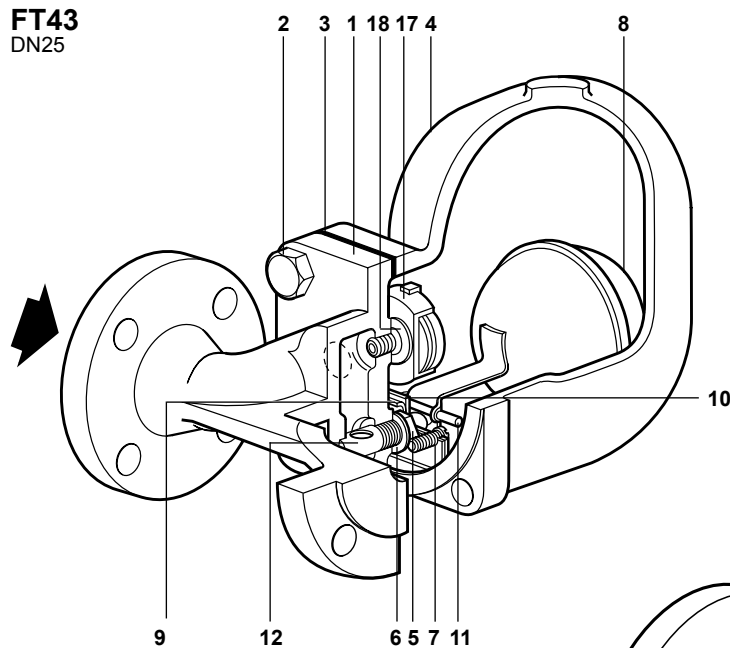

FT43-C

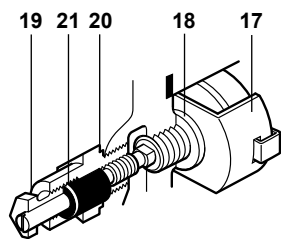

FT43

DN40 and DN50

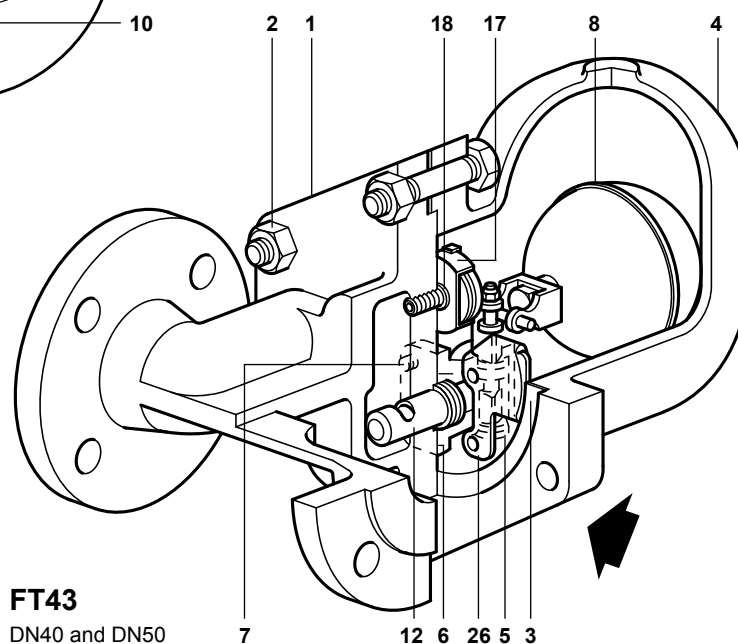

Materials

No.	Part		Material	
1	Body		Cast iron	EN-JL 1040
	Cover bolts	DN25	Steel	BS 3692 Gr. 8.8
2	Cover stud		Steel	BS 4882 - B7M
	Cover nuts		Steel	BS 3692 Gr. 8.8
3	Cover gasket		Reinforced exfoliated graphite	
4	Cover		Cast iron	EN-JL 1040
	Valve seat	DN25	Stainless steel	BS 970 431 S29
5	Main valve assembly with erosion deflector	DN40, DN50	Stainless steel	BS 3146 Part 2 Anc 2
	Valve seat gasket	DN25	Stainless steel	BS 1449 304 S11
6	Main valve assembly gasket	DN40, DN50	Reinforced exfoliated graphite	
	Pivot frame assembly bolts	DN25	Stainless steel	BS 4183 18/8
7	Main valve assembly bolts	DN40	Stainless steel	BS 970 304 S16
	Studs and nuts	DN50	Stainless steel	BS 6105 A4.80
	Ball float and lever	DN25	Stainless steel	BS 1449 304 S16
8	Ball float	DN40, DN50	Stainless steel	BS 1449 304 S16
9	Support frame		Stainless steel	BS 1449 304 S16
10	Pivot frame		Stainless steel	BS 1449 304 S16
11	Pivot pin		Stainless steel	
12	Erosion deflector		Stainless steel	BS 970 431 S29
17	Air vent assembly		Stainless steel	
18	Air vent seat gasket		Stainless steel	BS 1449 409 S19
19	SLR assembly		Stainless steel	BS 970 303 S21
20	SLR gasket		Mild steel	BS 1449 CS4
21	SLR seal		Graphite	
26	Inlet plate	DN40, DN50	Stainless steel	BS 1449 304 S15

Capacities

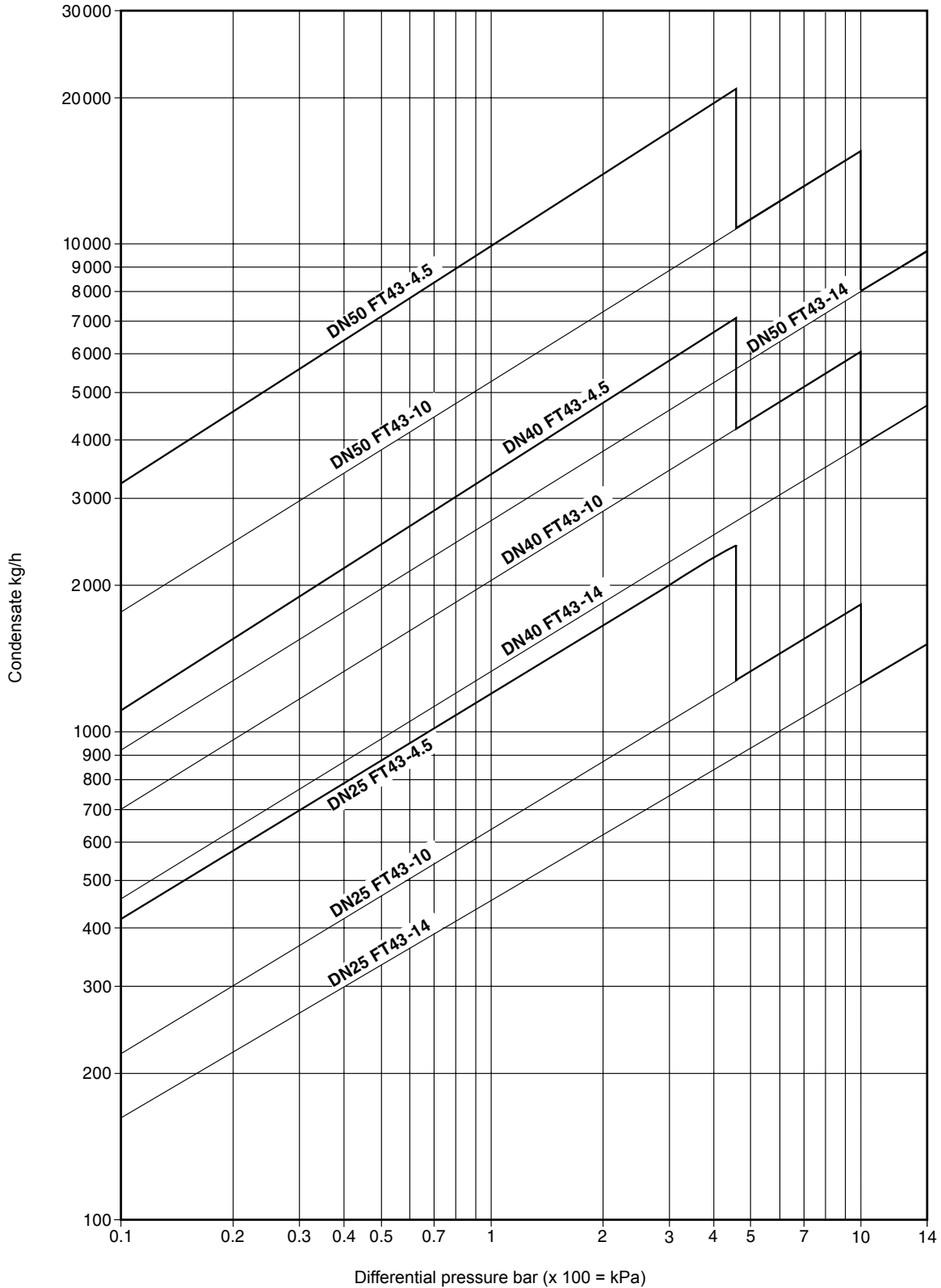

Additional cold water capacities from the thermostatic air vent under start-up conditions

Capacities shown above are based on condensate at saturation temperature. Under start-up conditions when the condensate is cold the internal thermostatic air vent will be open and provides additional capacity to the main valve. The following table gives the minimum additional cold water capacities from the air vent.

ΔP (bar)	0.5	1	2	3	4.5	7	10	14
	Minimum additional cold water capacity (kg/h)							
DN25, DN40 and DN50	460	680	900	1 080	1 300	1 600	1 980	2 050

FT43

DN40 and DN50 shown

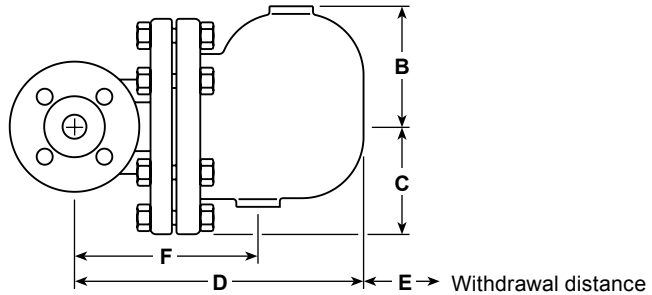
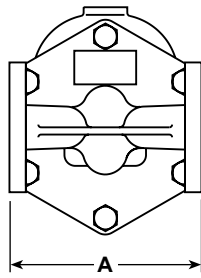

Dimensions / weights (approximate) in mm and kg

Size	A*		B	C	D	E	F	Weight
	PN16 JIS/KS 10	ASME 125						
DN25	160	148	110	80	245	160	215	8.3
DN40	230	221	128	110	330	200	200	21.5
DN50	230	220	140	126	340	200	225	30.5

* The face-to-face dimensions for the PN16 are in accordance with ISO 6554; for other flange variants, please contact Spirax Sarco.

Safety information, installation and maintenance

For full details see the Installation and Maintenance Instructions (IM-S02-30) supplied with the product.

Installation note:

The FT43 must be installed with the direction of flow as indicated on the body, and with the float arm in a horizontal plane so that it rises and falls vertically.

Disposal

This product is recyclable. No ecological hazard is anticipated with the disposal of this product providing due care is taken.

How to order

Example: 1 off Spirax Sarco DN25 FT43-4.5 ball float steam trap, flanged to EN 1092 PN16 with cast iron body and cover with thermostatic air vent.

Spare parts

The spare parts available are shown in solid outline. Parts drawn in broken line are not supplied as spares.

Available spares

Main valve assembly complete with ball float (DN25 horizontal traps)*	5, 6, 7, 8, 9, 10, 11
Main valve assembly with erosion deflector (DN40 and DN50) ** (specify horizontal or vertical trap)	5, 6, 7, 12, 26
Ball float (DN40 and DN50)	8
Air vent assembly	17, 18
Manually adjustable needle valve and air vent assembly	17, 18, 19, 20, 21
Complete set of gaskets (packet of 3)	3, 6, 20

* On horizontal traps the erosion deflector on the DN25 is pressed into the body during manufacture and not available as a spare.

** There is no erosion deflector on vertical traps.



How to order spares

Always order spares by using the description given in the column headed 'Available spares' and state the size and type of trap, including pressure range and orientation i.e. horizontal or vertical connections.

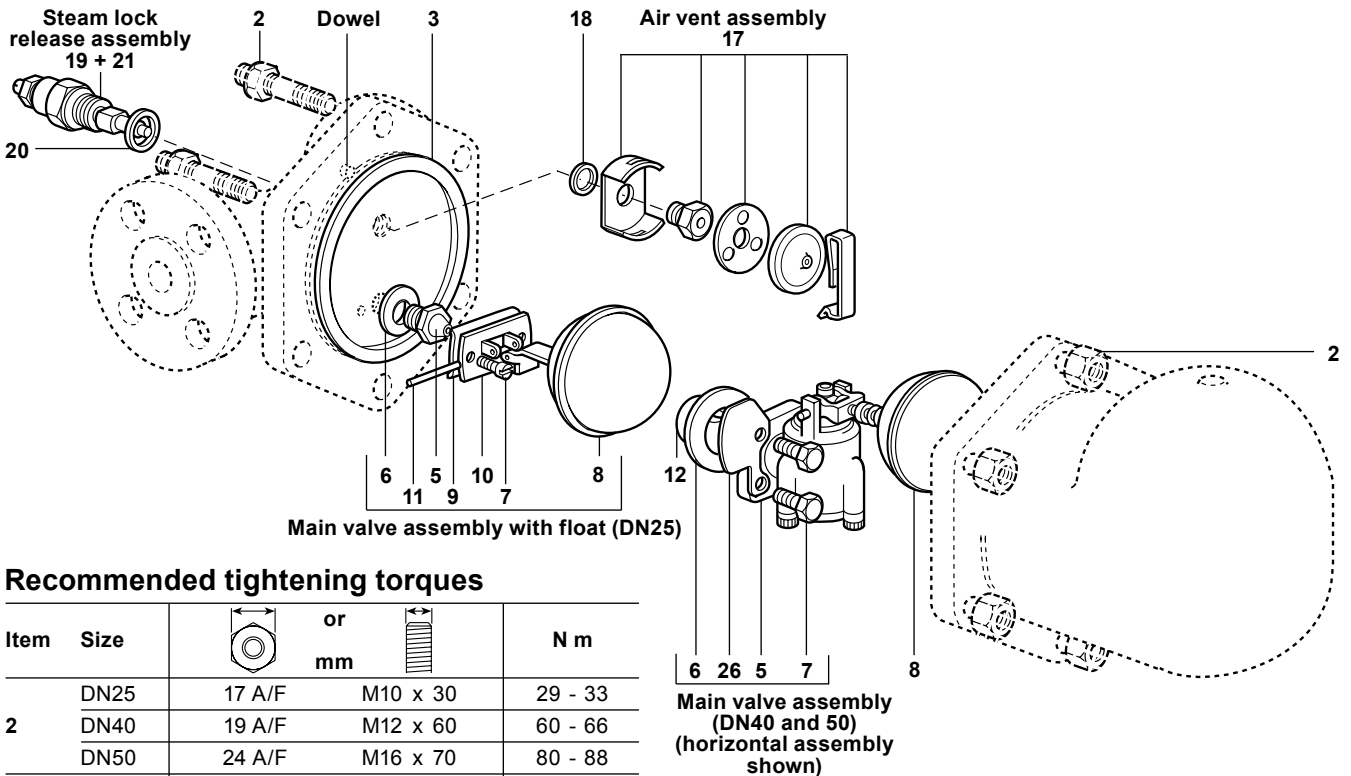
Example: 1 - Air vent assembly for a Spirax Sarco DN25 FT43-4.5 ball float steam trap, with horizontal connections.



Recommended tightening torques

Item	Size		or mm		N m
2	DN25	17 A/F		M10 x 30	29 - 33
	DN40	19 A/F		M12 x 60	60 - 66
	DN50	24 A/F		M16 x 70	80 - 88
5	DN25				50 - 50
	DN25			M5 x 20	2.5 - 2.8
7	DN40	10 A/F		M6 x 20	10 - 12
	DN50	13 A/F		M8 x 20	20 - 24
17		17 A/F			50 - 55
19		22 A/F			50 - 55