

# Pneumatic Control Valve Type 3522-1 and Type 3522-7



## Globe Valve Type 3522 ANSI Class 300



*Fig. 1 · Type 3522-7 Control Valve with integrated positioner*

## Mounting and operating instructions

**EB 8822**

Edition January 2002

<b>Contents</b>	<b>Page</b>
<b>1. Design and principle of operation</b> . . . . .	<b>4</b>
<b>2. Assembly of valve and actuator, adjustment</b> . . . . .	<b>6</b>
2.1 Option of preloading springs in actuator with "Actuator stem extends" . . . . .	7
2.2 Actuator springs preloaded by the manufacturers . . . . .	7
<b>3. Installation</b> . . . . .	<b>7</b>
3.1 Position of installation . . . . .	7
3.2 Strainer and bypass . . . . .	7
3.3 Signal pressure line . . . . .	8
<b>4. Operation</b> . . . . .	<b>8</b>
<b>5. Troubleshooting</b> . . . . .	<b>8</b>
5.1 Replacing the packing, plug and seat . . . . .	8
<b>6. Description of nameplates</b> . . . . .	<b>11</b>
<b>7. Customer inquiries</b> . . . . .	<b>11</b>



- ▶ *Assembly, start-up and operation of the device may only be performed by trained and experienced personnel familiar with this product.*
  - ▶ *According to these Mounting and operating instructions, trained personnel is referred to persons who are able to judge the work they are assigned to and recognize possible dangers due to their specialized training, their knowledge and experience as well as their knowledge of the relevant standards.*
  - ▶ *Any hazards which could be caused by the process medium, the signal pressure and moving parts of the control valve are to be prevented by means of appropriate measures.*
  - ▶ *In addition, you are required to make sure that the control valve is only used for applications where operating pressure and temperatures do not exceed the operating values that are based on the valve sizing data submitted in the order.*
  - ▶ *Proper shipping and appropriate storage are assumed.*
-

### 1. Design and principle of operation

The Type 3522-1 and Type 3522-7 Pneumatic Control Valves consist of a single-seated Type 3522 Globe Valve and either Type 3271 or Type 3277 Pneumatic Actuator for integral positioner attachment.

The modular design makes it possible to exchange the actuators.

The process medium flows through the valve in the direction indicated by the arrow. The position of the plug (3) is changed by the signal pressure (bench range) acting on the diaphragm in the actuator.

Plug (3) and actuator stem (8.1) are connected by the stem connector (7) and sealed by the spring-loaded ring packing (4.2).

#### Fail-safe position

The control valve has two different fail-safe positions depending on how the compression springs are arranged in the actuator:

##### Actuator stem extends

When the signal pressure is reduced or power supply fails, the compression springs force the actuator stem to move downward, closing the valve.

When the signal pressure increases, the valve opens by acting against the force of the compression springs.

##### Actuator stem retracts

When the signal pressure is reduced or power supply fails, the compression springs force the actuator stem to move upward, opening the valve.

When the signal pressure increases, the valve closes by acting against the force of the compression springs.

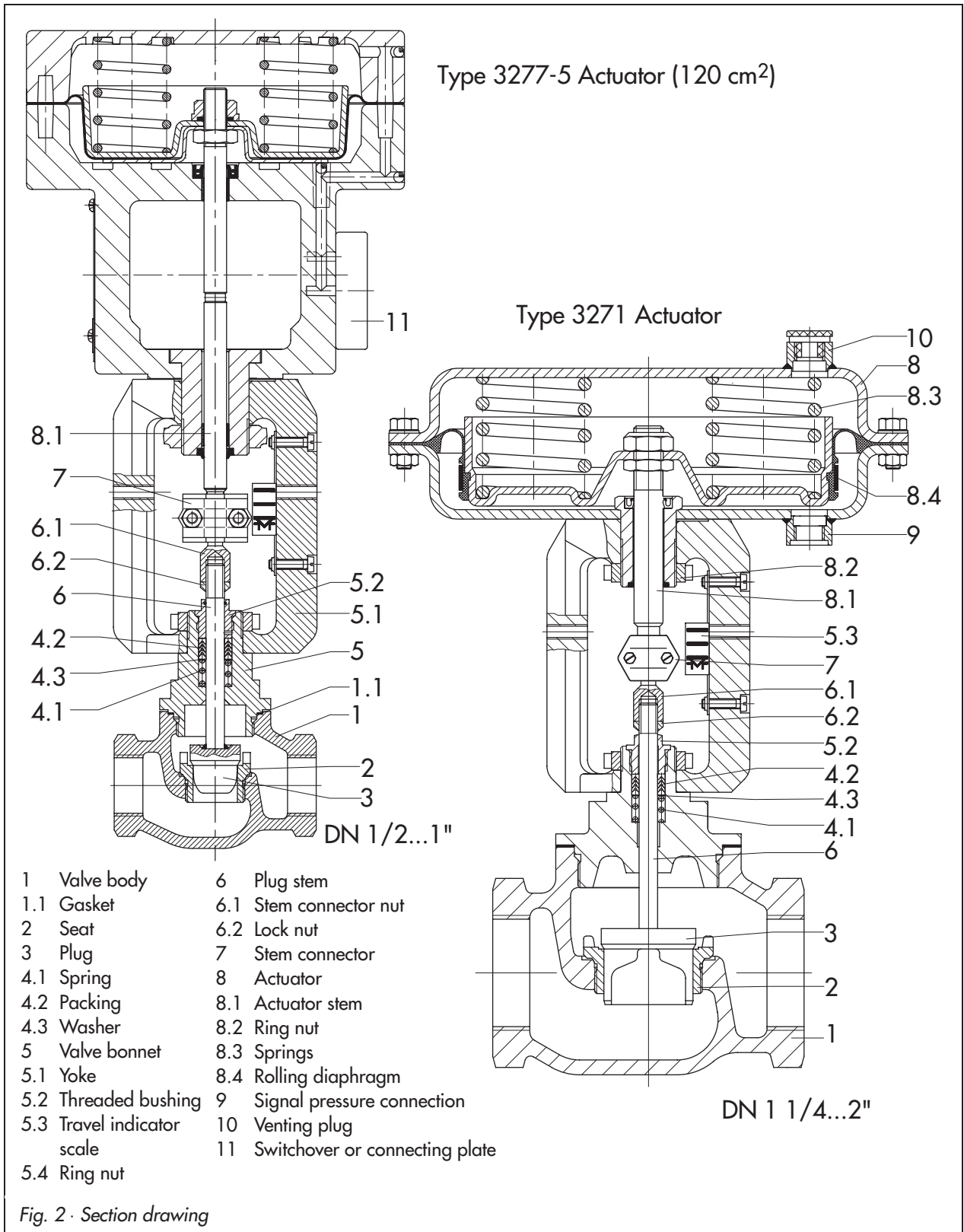

### 2. Assembly of valve and actuator, adjustment

In case the valve and actuator have not been assembled by the manufacturer, or the actuator of a control valve is to be exchanged for an actuator of another type or size, proceed as described below:

1. Unthread the lock nut (6.2) and the stem connector nut (6.1) at the valve. Press the plug and plug stem firmly into the seat and thread the lock nut and stem connector nut downward.
2. Remove the stem connector clamps (7) and the ring nut (8.2) from the actuator. Slide the ring nut over the plug stem.
3. Place the actuator on the bonnet (5) and secure with ring nut (8.2).
4. Read the bench range and the actuator's fail-safe action specified on the nameplate of the actuator. This could be, e.g. 0.2 to 1 bar and "Actuator stem extends".

The fail-safe action "Actuator stem extends" or "Actuator stem retracts" is marked on the nameplate as FA or FE on the Type 3271, and by a symbol on the Type 3277.

The lower range value of the signal range corresponds to the lower bench range value to be adjusted, and the upper range value to the upper bench range value.

5. For actuators with "Actuator stem extends", apply a signal pressure that corresponds to the lower bench range value (e.g. 0.2 bar) to the lower diaphragm chamber.

For actuators with "Actuator stem retracts", apply a signal pressure that corresponds to the upper bench range value (e.g. 1 bar) to the upper diaphragm chamber.

6. Thread down the stem connector nut (6.1) by hand until it contacts the actuator stem (8.1). Then make another 1/4 turn and secure this position with the lock nut (6.2).
7. Position the stem connector clamps (7) and screw tight. Align the travel indicator scale (5.3) with the tip of the stem connector. For actuators with "Actuator stem extends", the bottom marking indicates valve closed and with "Actuator stem retracts" the top marking indicates valve open.

---

#### Note on disassembling actuators

*Prior to disassembling the actuator "Actuator stem extends" and, in particular, an actuator with preloaded springs, you have to apply a pressure that slightly exceeds the lower bench range value (see nameplate) to the signal pressure connection on the lower diaphragm chamber.*

---

## 2.1 Option of preloading springs in actuator with "Actuator stem extends"

To obtain a more powerful positioning force, the springs of these actuators can be preloaded by up to 12.5% (25% for 350 cm<sup>2</sup>) of their travel or their bench range.

When the springs are to be preloaded by, for example, 12.5%, for a bench range of 0.2 bar to 1 bar (3 to 15 psi), the bench range is shifted by 0.1 bar, resulting in a bench range of 0.3 to 1.1 bar (0.1 bar corresponds to a preload of 12.5 %).

On adjusting the valve, the lower bench range value must now be set to 0.3 bar (5 psi). The newly adjusted bench range of 0.3 to 1.1 bar (5 to 17 psi) must be indicated on the nameplate as bench range with preloaded springs.

## 2.2 Actuator springs preloaded by the manufacturer

Actuators that have been preloaded by the manufacturer without a valve being attached, are marked with a label.

In addition, you will notice three extended bolts with nuts on the diaphragm case. They allow the preload springs to be unloaded evenly on disassembling the actuator.

## 3. Installation

### 3.1 Position of installation



#### **Important!**

*The valve must be installed vertically with the actuator pointing upward and must be installed free of stress. If necessary, support the pipeline near to the valve connections. Do not mount supports on the valve or actuator.*

*Thoroughly flush the pipelines prior to installation of the valve.*

### 3.2 Strainer and bypass

Install a strainer (SAMSON Type 2 Strainer) upstream of the valve since sealing particles, globules and other impurities carried along by the process medium could impair the proper functioning of the valve, especially tight shut-off.

The strainer must be installed so that the medium flows through it in the direction indicated by the arrow on the strainer body. The filter insert must be vertically suspended. Make sure that ample space is available to remove the filter.

We recommend that you install a shut-off valve both upstream of the strainer and downstream of the valve as well as a bypass so that you need not shut down the plant for maintenance routines.

### 3.3 Signal pressure line

**Type 3271 Actuator:** Connect the signal pressure line for valves with actuator "Actuator stem extends" to the lower diaphragm case, and for valves with actuator "Actuator stem retracts" to the upper diaphragm case.

**Type 3277 Actuator:** For actuators with integral positioner attachment, refer to the corresponding mounting and operating instructions for signal pressure connection.

### 4. Operation

For reversing the operating direction (fail-safe action) of the pneumatic actuator, refer to the mounting and operating instructions of the actuators:

for Type 3271 EB 8310 EN and  
for Type 3277 EB 8311 EN

## 5. Troubleshooting

If you notice leakage, this could be caused by a damaged packing (4.2).

If the valve does not properly close, this could be caused by dirt or other impurities caught between the seat and plug, or by damaged sealing edges.

You should disassemble the parts in question, thoroughly clean them and replace them as necessary.



#### **Caution!**

*Before servicing or disassembling the control valve, you are required to relieve the corresponding section of the plant from pressure and drain it.*

*You should remove the control valve from the pipeline.*

*Allow the section of plant to cool down before starting.*

---

### 5.1 Replacing the packing, plug and seat



#### **Note:**

*Prior to carrying out any service work on the valve body, first remove the actuator.*

*Repairs should only be carried out after the valve has been removed from the pipeline!*

---

1. For actuators with "Actuator stem extends", first apply a pressure that exceeds the lower bench range value (see nameplate). This takes the load off the



actuator springs and lets you unscrew the ring nut (8.2) easily.

2. Remove the stem connector clamps (7) between the actuator stem and plug stem and unthread the ring nut (8.2).
3. Disconnect the supply pressure and lift the actuator off the valve.
4. Remove the nuts (6.1 and 6.2).
5. Unthread the threaded bushing (5.2) from the valve bonnet.

If you just want to replace the packing, you can attempt to slide up the packing parts by moving the plug stem.

If it is not possible to remove the packing parts in this way or the plug and seat must be replaced, separate the valve bonnet and valve body.

6. Clamp the valve body, place a suitable wrench at the hexagon of the valve bonnet and unscrew it from the valve body.
7. Pull plug with plug stem out of the valve bonnet.

Remove the packing rings (4.2), washer (4.3) and spring (4.1) using an appropriate tool.

Clean the packing chamber thoroughly.

8. Replace damaged parts with new ones. If the valve seat has to be replaced, unscrew it from the body using the appropriate seat wrench listed in the table (page 10).

Apply lubricant (order no. 8150-0119) to the thread and sealing cone of the new seat and screw it into the valve

body, observing the tightening torque listed in the table.

9. Apply lubricant (order no. 8150-0111) to the plug at the plug stem and push it into the valve bonnet.
10. Apply lubricant (order no. 8150-0119) to the new gasket (1.1) and thread of the valve bonnet (5), place it on the val-

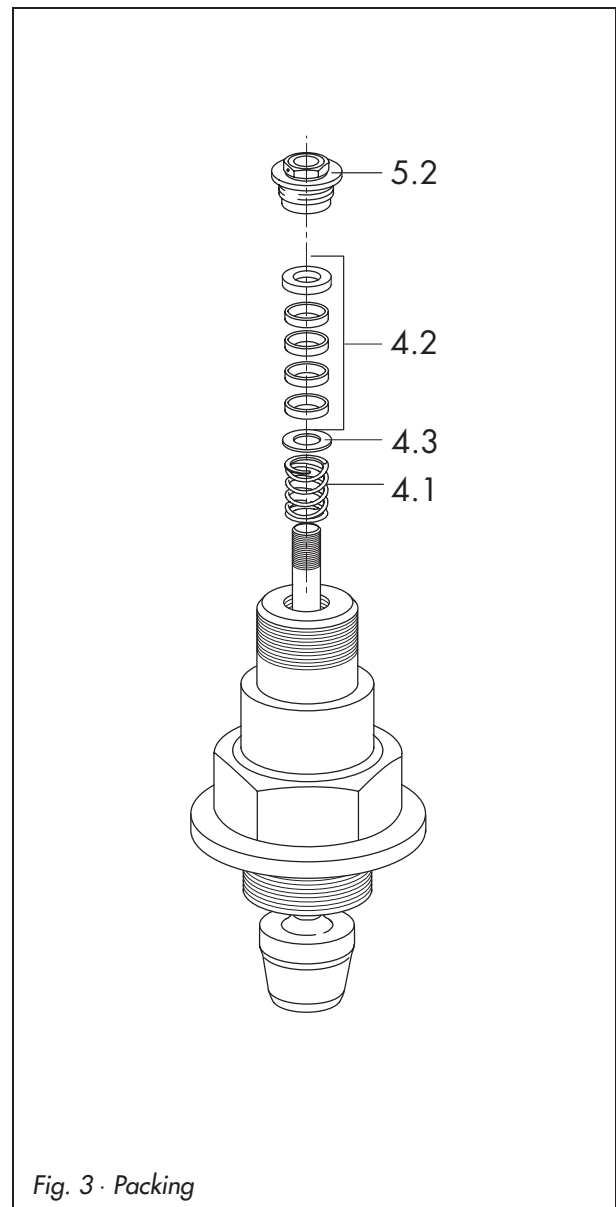

ve body and screw tight (observing the tightening torque in the table).

11. Apply lubricant (order no. 8150-0111) to the spring (4.1), washer (4.3) and new packing rings (4.2) as well as the threaded bushing (5.2) and slide them over the plug stem into the packing chamber.  
Screw the threaded bushing (5.2) in as far as it will go.
12. Loosely screw the lock nut (6.2) and stem connector nut (6.1) onto the plug stem (6).
13. Mount the actuator and adjust the lower and upper bench range values as described in chapter 2.

**Dimensions**

*Refer to the Data Sheet T 8822 EN for dimensions and weights of the valve versions.*

<b>Table of seat wrenches and tightening torques</b>				
Nominal size DN	Seat wrench	Tightening torque Seat [Nm]	Tightening torque for valve bonnet [Nm] Body material	
	Order no.		Bronze	Stainless steel
1/2"...1"	9110-2403	170	200	
1 1/4"...2"	9110-2464	500	1 1/4 and 1 1/2" = 500 2" = 700	

## 6. Description of nameplates

Type 3522 Valve

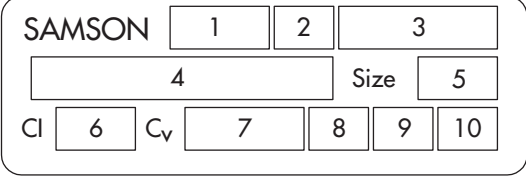

Type 3271 Actuator

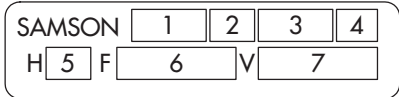

Type 3277 Actuator

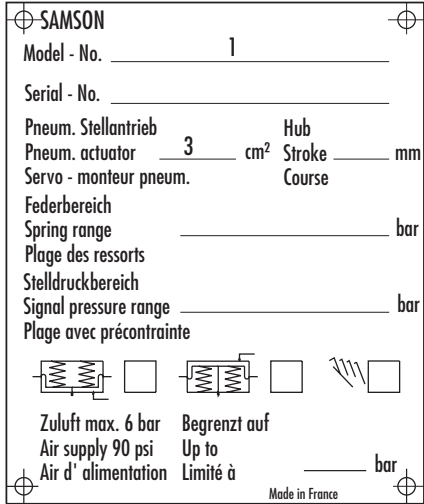

1 Type designation  
2 Modification index of the device  
3 Material  
4 Order number with modification index  
5 Nominal size  
6 ANSI Class  
7 Cv value  
8 Characteristic EP = Equal percentage  
9 Sealing ME metal  
10 Pressure balance, flow divider

1 Type designation  
2 Modification index  
3 Effective area  
4 Fail-safe action:  
With Type 3271: FA Actuator stem extends,  
FE Actuator stem retracts  
With Type 3277: left: Actuator stem extends  
right: Actuator stem retracts  
5 Travel  
6 Bench range (spring range)  
7 Bench range with preloaded springs

Fig. 4 · Nameplates on valve and actuators

## 7. Customer inquiries

Should you have any questions, please submit the following details:

- ▶ Type designation and production number
- ▶ Nominal size and valve version
- ▶ Pressure and temperature of the process medium
- ▶ Flow rate in m<sup>3</sup>/h
- ▶ Bench range (signal pressure range) e.g. 0.2 to 1 bar, of the actuator
- ▶ Installation drawing



SAMSON CONTROLS INC.  
1 - 105 Riviera Drive  
Markham · Ontario · Canada · L3R 5JR  
Tel. (905) 474-0354 · Fax (905) 474-0998

SAMSON CONTROLS INC.  
4111 Cedar Boulevard  
Baytown · Texas · USA · 77520-8588  
Tel. (281) 383-3677 · Fax (281) 383-3690

**EB 8822**

EB 8822 CA