

C- Reassembling NEOS DCX3 valves.

Check that the seal-bearing surface inside the body (1) is clean. Put the valve in the "open" position. With an N.C. configuration, supply the operator sub-assembly (6) with air and insert in the body, making sure the plug seal is not damaged around the part edges. Refit the clamp (9). When using for the first time, check the lower connection and top connection(s) for leaks.

NOTE:

- We recommend using a **medium threadlock compound** to lock the plug during reassembly on the operator and retightening the plug of diaphragm valves after first use at temperature.
- During sawing operations, prevent chips or filings from entering the pipes and rinse the pipes thoroughly with the valve open to avoid damaging the seals when the valve is put into service.
- **IMPORTANT:** Please **reconnect the leak collector end fitting** of the lantern to channel any spillage of product in the event of diaphragm failure.

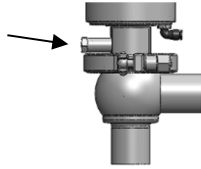

8) STORAGE

We recommend that our valves are stored away from site pollution (abrasive dust, shocks, acid or chlorinated products, U.V., etc.) for as long as possible and are mounted to prevent mixtures of components.

9) SPARE PARTS AND ACTUATOR DISASSEMBLY

We can provide you with the component references for your valve on request. You can also make a note of the valve identification number.

Actuator disassembly is a simple but delicate operation requiring the use of the appropriate tools and reference to the valve disassembly instructions.

Please contact us for these instructions or to request maintenance operations at our premises or on site.

N.B.: The valve must be out of service prior to any intervention and disassembly of the components with the pretensioned spring must be performed in accordance with the instructions on the maintenance information sheet.

10) EEC CONFORMITY

A - Our valves comply with European regulations (EEC) within the limits of use described in paragraph B.
The CE mark on the valve indicates conformity to the following regulations:

CE - 89/336 "Electromagnetic compatibility"
- 97/23 "Pressure equipment"
- 73/23 "Low Voltage"
B- Use limits:

Usage pressure must be lower than 10 bar for all products.

In case of dangerous gas⁽¹⁾ valve diameter (line) must be below 100 mm.

For use outside these limits, please contact our technical service

⁽¹⁾hazardous gas: group 1 gas, identified by a letter on the label and on the security card of the product:

E (for detonating gas), O (for fuel), F+, F and R10 (flammable), T+ and T (toxic).

For additional information, please see regulation 67/548/EC "Labelling of dangerous products".



INSTALLATION GUIDE

NEOS DCX 3 CHANGEOVER VALVE

www.definox.com

DEFINOX SAS

3 Rue des Papetiers - Z.A.C. de Tabari 2

44190 Clisson - France

☎ : +33 (0)2 28 03 98 50

📠 : +33 (0)2 28 03 88 00

E-mail: info@definox.com

NEOS DCX 3 VALVE

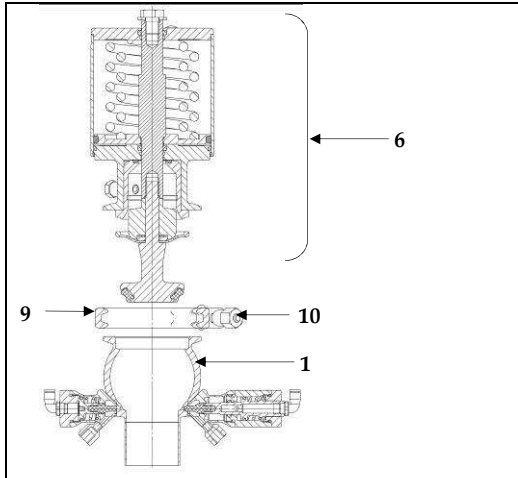

- 1: NEOS body + leakage and washing assembly (washing control optional)
- 2: NEOS plug
- 3: Diaphragm seal support plate
- 4: Diaphragm washer
- 5: Diaphragm intermediate part
- 6: Shut-off subassembly
- 7: Valve actuator
- 8: NEOS seal
- 9: Collar
- 10: Collar screw
- 11: Diaphragm
- 12: Spring washers
- 13: Ring
- 14: O-ring

DETAIL of Ref. 12

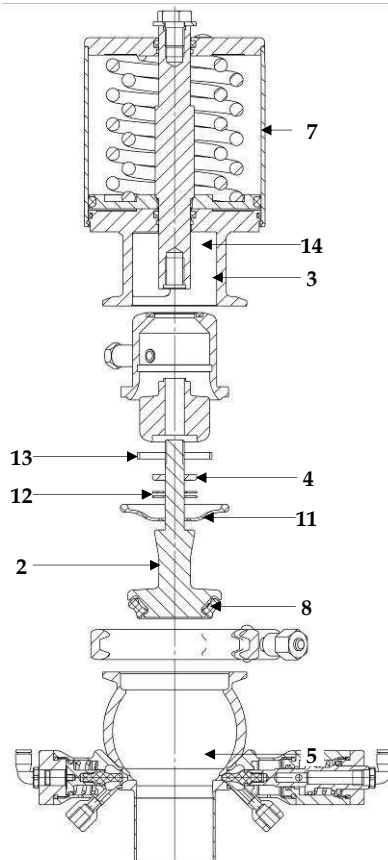
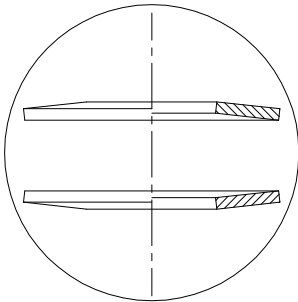

For trouble-free installation of your DEFINOX NEOS DCX3 valve, we recommend that you read these instructions which describe the main steps required to put your valve into service and include a number of handy tips{HS}:

1) VALVE IDENTIFICATION

DEFINOX changeover valves have an identification number. You will need this number in order to identify the spare parts you may request.

2) WORKING CONDITIONS

The working conditions of this valve (pressure, temperature, fluid transported, etc.) must comply with the general technical specifications described in the DEFINOX catalogue available on request.

3) AIR SUPPLY CONDITIONS

The actuator is supplied with dry, filtered air at a pressure of 4.5 to 8 bar. The operator air couplings are designed for a 4/6 diameter hose fitting. The valve has a max. working pressure of 6 bar, a max. temperature of 140°C and an acceptable vacuum of 0.4 bar.

4) SEALS

Unless otherwise specified in the order, NEOS DCX3 valves are equipped with the following seals:

- PFA for plug seals
- PFA for the diaphragm

5) N.C. - N.O. - AND D.A CONFIGURATION

DCX3 / 4 valves are supplied as standard in a N.C. configuration and require an air supply to remove the plug. The valves can be supplied in a N.O. or D.A. configuration on request.

Important: Before changing the configuration, consult the maintenance instructions (IT.DFX.270)

6) PRECAUTIONS TO BE TAKEN WHEN WELDING THE BODIES

Adjust the pipes: check the perpendicularity, out-of-roundness and offset (play < 0.5 mm to limit stresses due to welding).

Any modifications to the valve body for welding must be made in agreement with Definox.

Support the pipework within 10D of the valve (Nominal valve diameter)

7) INSTALLING THE VALVE ON THE PROCESS LINE

To install the valve on the process line, **the weld-on body must be separated**, from the rest of the valve to prevent seal damage.

To carry out this simple operation, proceed as follows while referring to the diagrams:

A- Disassembling NEOS DCX3 valves.

Put the valve in the "open" position. With an N.C. configuration, the shut-off sub-assembly operator (6) must be supplied with air. Remove the clamp (9). Shut off the air and separate the body (1) from the rest of the valve. Weld the body to the pipes.

.../...

IMPORTANT: To change the actuator configuration, please refer to the disassembly instructions or contact our Technical Department.