

Series 42 Self-operated Pressure Regulators

Type 42-20 and Type 42-25 Differential Pressure Regulators

with Type 2420/Type 2425 Actuator (opening) and balanced Type 2422 Valve



ANSI version

Application

Differential pressure regulators for large heating systems and industrial plants · Differential pressure set points Δp from **0.75** to **145 psi** (0.05 to 10 bar) · Valves **NPS ½ to 10**¹⁾ (DN 15 to 250) · Pressure rating **Class 125** to **300** · Suitable for **liquids** and **vapors**²⁾ from **40** to **660 °F** (5 to 350 °C), for **air** and non-flammable gases up to **175 °F** (80 °C)



The valve **opens** when the differential pressure **rises**.

The differential pressure to be controlled is transmitted to the spring-loaded operating diaphragm in the actuator and converted into a positioning force to move the valve plug. The regulators control the differential pressure according to the adjusted set point.

Special features

- Low-noise, medium-controlled proportional regulator requiring little maintenance
- **Type 42-20**: Fixed set point
Type 42-25: Set point adjustable in wide range
- Single-seated valve with a plug balanced by a stainless steel bellows or a diaphragm (NPS 2½ to 10/DN 65 to 250)
- Suitable for circuit water, water/glycol mixtures, steam and air as well as other liquids, gases and vapors, provided these do not affect the characteristics of the operating diaphragm
- Valve body optionally made of cast iron A126B, cast steel A216 WCC or cast stainless steel A351 CF8M

Versions

Differential pressure regulators for installation in a bypass pipe or short-circuit pipe (see Application) · Flanged connections

Type 42-20 (Fig. 1) · Type 2422 · Balanced by a bellows NPS ½ to 4 (DN 15 to 100) · Balanced by a diaphragm NPS 2½ to 4 (DN 65 to 100) · Type 2420 Actuator · Fixed set point, adjusted to $\Delta p = 3, 4, 6$ or 7 psi (0.2, 0.3, 0.4 or 0.5 bar)

Type 42-25 (Fig. 2) · Type 2422 Valve · Balanced by a bellows NPS ½ to 10 (DN 15 to 250) · Balanced by a diaphragm NPS 2½ to 10 (DN 65 to 250) · Type 2425 Actuator · Set point adjustable within the range between 0.75 to 145 psi (0.05 to 10 bar)

¹⁾ Valves larger than NPS 10 (DN 250) on request

²⁾ Version balanced by a bellows only



Fig. 1: Type 42-20 Differential Pressure Regulator



Fig. 2: Type 42-25 Differential Pressure Regulator

Special versions

Actuator with two diaphragms (Type 42-25) · Version with FPM diaphragm, e.g. for mineral oil · Special reduced C_V (K_{VS}) coefficient · Valve in corrosion-resistant version (min. material grade 1.4301) · Valves larger than NPS 10 (DN 250) · Version for temperatures above 430 °F (220 °C) · Backflow prevention (▶ T 3010) · Version for deionized water · Version free of non-ferrous metal · Version for small flow rates · Valve with micro trim with C_V 0.0012 to 0.05 (K_{VS} 0.001 to 0.04) or C_V 0.12, 0.5 and 1.2 (K_{VS} 0.1, 0.4 and 1) without pressure balancing

Accessories

Required accessories, such as compression-type fittings, needle valves, equalizing tanks and control lines, are listed in Data Sheet ▶ T 3095.

Principle of operation (see Fig. 3)

The medium flows through the valve in the direction indicated by the arrow. The position of the valve plug (3) determines the differential pressure over the cross-sectional area released between the plug (3) and seat (2).

The Type 2422 Valve is balanced. The forces acting on the valve plug created by the upstream and downstream pressures are balanced by a balancing bellows (5) or balancing diaphragm (5.1).

In valves balanced by a bellows, the upstream pressure p_1 acts on the outside of the metal bellows (5), while the downstream pressure p_2 acts on the inside of the bellows. In a valve balanced by a diaphragm, the downstream pressure p_2 acts

on the inside and the upstream pressure p_1 on the outside of the balancing diaphragm (5.1). In both cases, the forces created by the upstream and downstream pressures acting on the valve plug are balanced out.

The differential pressure to be controlled is transferred to the operating diaphragm (13) where it is transformed into a positioning force. This force is used to move the plug (3) according to the force of the set point springs.

In Type 42-25, the set point can be adjusted at the set point adjuster (17).

In Type 42-20, the set point springs (16) in the actuator determines the set point.

All versions have control lines to transfer the high pressure and low pressure to the actuator.

SAMSON offers a special version of Type 42-25 Regulator with an actuator with two diaphragms, which is especially suitable for applications with thin oils (e.g. heat transfer oil).

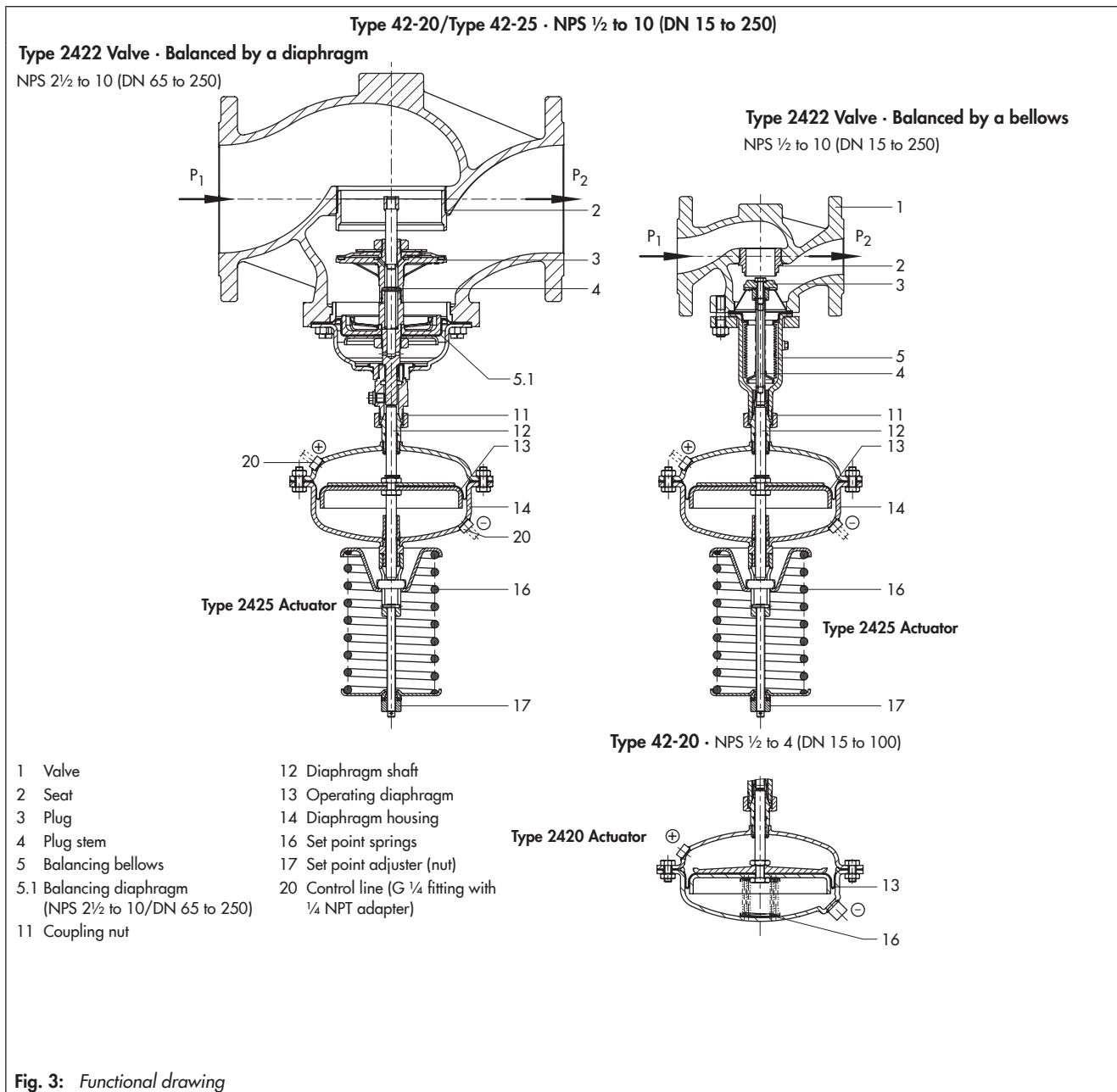

Type 42-25 Differential Pressure Regulator with two diaphragms

SAMSON offers a special version of Type 42-25 Regulator with an actuator with two diaphragms, providing increased functional safety.

The two diaphragms separate both diaphragm chambers connected to the high-pressure and low-pressure connections. They generate a positioning force from the differential pressure. A mechanical diaphragm rupture indicator (22) is located between the two diaphragms, which responds at approx. 22 psi (1.5 bar). In the event of a diaphragm rupture, the pressure in the space between the two operating diaphragm starts to increase. This causes the pin in the diaphragm rupture indicator to be pushed outwards and a red ring appears, indicating the diaphragm rupture. The intact operating diaphragm takes on the control task of the ruptured diaphragm.

A pressure switch can be optionally mounted to the actuator to trigger an alarm.

If a diaphragm rupture is indicated, we recommend replacing both diaphragms.

Installing the valve and mounting the actuator

Valve and actuator are delivered unattached.

A coupling nut is used to attach the actuator to the valve. The actuator is to be mounted preferably after the valve is installed in the pipeline.



The following points must be observed:

- Installation of the valve in horizontal pipelines
- Direction of flow must match the direction indicated by the arrow on the body
- Install a strainer (e.g. SAMSON Type 2 NI) upstream of the valve.

Application

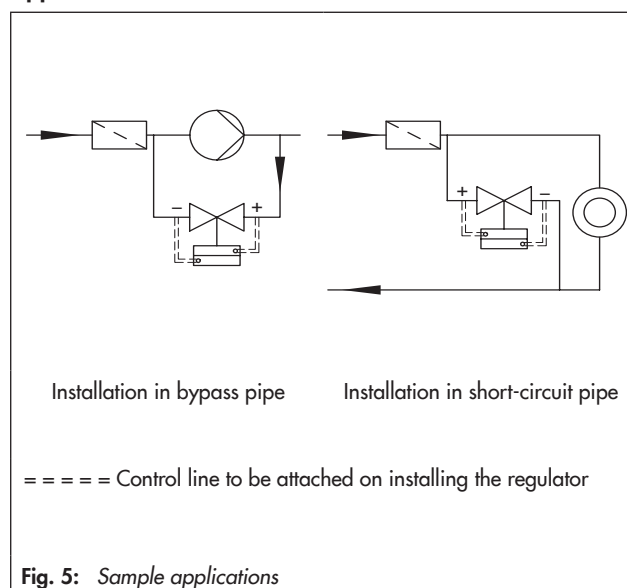
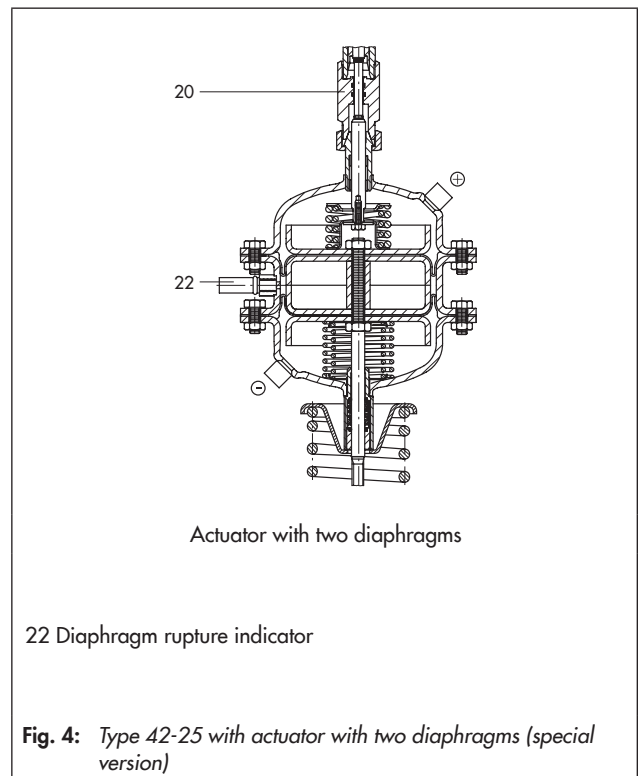

Fig. 5: Sample applications



Permissible mounting positions

- Actuator suspended downwards (see photo): Standard installation, all versions, above 175 °F (80 °C) and for applications with steam
 - Actuator upright (actuator on top of the valve): All versions NPS 1/2 to 3 (DN 15 to 80) and max. 175 °F (80 °C)
 - Actuator sideways: Only versions with fixed plug guide
- Refer to ► EB 3007 for details.

Table 1: Technical data

Type	42-25				42-20	
Valve size	NPS ½ to 10 · DN 15 to 250				NPS ½ to 4 · DN 15 to 100	
Pressure rating	Class 125, 150 and 300					
Max. permissible temperature	Valve	See pressure-temperature diagram in ► T 3000				
	Actuator ¹⁾	With compensation chamber: Steam and liquids up to 660 °F (350 °C) ²⁾ Without compensation chamber: Liquids up to 300 °F (150 °C) · Air and gases up to 175 °F (80 °C)				
Set point ranges	psi	0.75 to 3.5 · 1.5 to 8.5 · 3 to 15 · 7 to 20 15 to 35 · 30 to 75 · 65 to 145			3, 4, 6 or 7	
	bar	0.05 to 0.25 · 0.1 to 0.6 · 0.2 to 1 · 0.5 to 1.5 1 to 2.5 · 2 to 5 · 4.5 to 10			0.2 · 0.3 · 0.4 or 0.5	
Actuator area A	12 in ² (80 cm ²)	25 in ² (160 cm ²)	50 in ² (320 cm ²)	100 in ² (640 cm ²)	25 in ² (160 cm ²)	50 in ² (320 cm ²)
Max. perm. operating pressure for actuator with two diaphragms	580 psi (40 bar)	580 psi (40 bar)	360 psi (25 bar)	360 psi (25 bar)	-	
Leakage class according to ANSI/FCI 70-2	≤0.05 % of C _v (K _{vS}) coefficient					
Compliance	CE · EAC					

¹⁾ Higher temperatures on request

²⁾ Steam version only with valves balanced by a bellows

Terms for control valve sizing according to IEC 60534, Parts 2-1 and 2-2: $F_L = 0.95$, $X_T = 0.75$

Table 2: Materials · Material numbers according to ASTM and DIN EN
Valve

Type 2422 Valve · Balanced by a bellows			
Valve size	NPS ½ to 10 · DN 15 to 250		
Pressure rating	Class 125	Class 150/300	Class 150/300
Valve body	Cast iron A126B	Cast steel A216 WCC	Cast stainless steel A351 CF8M
Valve seat	Stainless steel 1.4104 or 1.4006		1.4404
Plug	Up to NPS 4 (DN 100)	Stainless steel 1.4104, 1.4112 or 1.4006 ¹⁾	
	NPS 6 to 10 (DN 150 to 250)	1.4404, with PTFE soft seal	
Plug stem	1.4301		
Metal bellows	1.4571 · NPS 6 (DN 150) and larger: 1.4404		
Bottom section	P265GH		1.4571
Body gasket	Graphite on metal core		
Type 2422 Valve · Balanced by a diaphragm			
Valve size	NPS 2½ to 4 · DN 65 to 100		
Pressure rating	Class 125	Class 150	
Valve body	Cast iron A126B	Cast steel A216 WCC	
Valve seat	1.4408		
Plug	CW617N		
Pressure balancing	Diaphragm plate EN-JS1030 · EPDM balancing diaphragm, max. 300 °F (150 °C) or NBR diaphragm, max. 175 °F (80 °C)		
Valve size	NPS 6 to 10 · DN 150 to 250		
Pressure rating	Class 125	Class 150/300	Class 150/300
Valve body	Cast iron A126B	Cast steel A216 WCC	Cast stainless steel A351 CF8M
Valve seat	CC491K/CC499K ²⁾		
Plug	CC491K/CC499K ²⁾ · With EPDM soft seal, max. 300 °F (150 °C) or with PTFE soft seal, max. 300 °F (150 °C)		
Pressure balancing	Diaphragm plate EN-JS1030 · EPDM balancing diaphragm, max. 300 °F (150 °C) or NBR diaphragm, max. 175 °F (80 °C)		

¹⁾ Optionally with soft seal with standard C_v (K_{vS}) coefficients

²⁾ Special version 1.4409

Type 2420/Type 2425 Actuator

Type 2420/Type 2425 Actuator			
Pressure rating	Class 125	Class 150/300	Class 150/300
Diaphragm cases	DD 11		1.4301
Diaphragm	EPDM ¹⁾ with fabric reinforcement		
Guide bushing	DU bushing		PTFE
Seals	EPDM/PTFE ¹⁾		

¹⁾ Special version, e.g. for mineral oils: FPM (FKM)

Table 3: C_V (K_{VS}) coefficients, x_{FZ} values and max. permissible differential pressures

Type 2422 Valve - Balanced by a bellows												
Valve size	NPS	½ ¹⁾	¾ ¹⁾	1 ¹⁾	1½	2	2½	3	4	6	8	10
	DN	15	20	25	40	50	65	80	100	150	200	250
Valve travel	0.4" (10 mm)						0.6" (16 mm)			0.9" (22 mm)		
Standard C_V (K_{VS}) coefficient	C_V	5	7.5	9.4	23	37	60	94	145	330	490	590
	K_{VS}	4	6.3	8	20	32	50	80	125	280	420	500
Max. perm. differential pressure Δp	360 psi (25 bar)						290 psi (20 bar)		230 psi (16 bar)	175 psi (12 bar)	145 psi (10 bar)	
Reduced C_V (K_{VS}) coefficient	C_V	–	–	5	9.4	20	32		60	145	330	
	K_{VS}	–	–	4	8	16	20		50	125	280	
Max. perm. differential pressure Δp	360 psi (25 bar)								290 psi (20 bar)	230 psi (16 bar)	175 psi (12 bar)	
x_{FZ} value	0.65	0.6	0.55	0.45	0.4			0.35			0.3	

¹⁾ Special valve version with micro-trim: C_V 0.0012 to 0.05 (K_{VS} 0.001 to 0.04) or C_V 0.12, 0.5 and 1,2 (K_{VS} 0.1, 0.4 and 1) without pressure balancing

Type 2422 Valve - Balanced by a diaphragm								
Valve size	NPS	2½	3	4	6	8	10	
	DN	65	80	100	150	200	250	
Valve travel	0.6" (15 mm)				1.4" (35 mm)			
C_V (K_{VS}) coefficient	C_V	60	95	150	445	760	930	
	K_{VS}	50	80	125	380	650	800	
Max. perm. differential pressure Δp	145 psi (10 bar)				175 psi (12 bar)		145 psi (10 bar)	
x_{FZ} value	0.4		0.35			0.3		

Dimensions

Dimensional drawing · Type 42-20 and Type 42-25 balanced by a bellows · See Table 4



Type 42-25 · Type 2422 Valve balanced by a bellows
with Type 2425 Actuator

Type 42-20 · Type 2422 Valve balanced by a bellows
with Type 2420 Actuator

Type 2422 Valve, balanced by a bellows

Fig. 6: Dimensions in mm · Valve balanced by a bellows

Dimensional drawing of actuator with two diaphragms

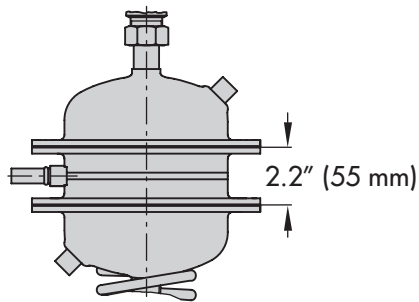

Type 42-25 with actuator with two diaphragms (special version). Add approx. 2.2" (55 mm) to the total height H.

Actuator with two diaphragms

Fig. 7: Dimensions in mm · Actuator with two diaphragms

Table 4: Dimensions and weights for Type 42-20 and Type 42-25 · Balanced by a bellows

Valve size		NPS	½	¾	1	1½	2	2½	3	4	6	8	10		
		DN	15	20	25	40	50	65	80	100	150	200	250		
Length L	Class 125/150	inch	7.25			8.75	10	10.9	11.75	13.9	17.75	21.4	26.5		
		mm	184			222	254	276	298	352	451	543	673		
	Class 300	inch	7.5	7.6	7.75	9.25	10.5	11.5	12.5	14.5	18.6	22.4	27.9		
		mm	190	194	197	235	267	292	318	368	473	568	708		
Height H1	inch	8.9					11.8			14	23.2	28.7			
	mm	225					300			355	590	730			
Height H2	inch	1.7			2.8			3.9		4.7	6.9	9.6	10.6		
	mm	44			72			98		118	175	245	270		
Type 42-20 Differential Pressure Regulator															
Set points		Type 2420 Actuator													
3, 4, 6, 7 psi (0.2, 0.3, 0.4, 0.5 bar)	Height H	15.4" (390 mm)					18.3" (465 mm)			20.5" (520 mm)					
	Actuator	ØD = 8.9" (225 mm) · A = 25 in ² (160 cm ²) ²⁾					ØD = 11.2" (285 mm) · A = 50 in ² (320 cm ²)								
	Weight ³⁾	lb	25	27	29	44	50	84	95	126	-				
		kg	11.5	12	13	20	22.5	38	43	57					
Type 42-25 Differential Pressure Regulator															
Set points		Type 2425 Actuator													
0.75 to 3.5 psi (0.05 to 0.25 bar)	Height H	24.6" (625 mm)					27.6" (700 mm)			29.7" (755 mm)	44.1" (1120 mm)	49.6" (1260 mm)			
	Actuator	ØD = 11.2" (285 mm) · A = 50 in ² (320 cm ²) ¹⁾					ØD = 11.2" (285 mm) A = 100 in ² (640 cm ²)			ØD = 15.4" (390 mm) A = 100 in ² (640 cm ²)					
	Weight ³⁾	lb	46	47	50	65	71	111	113	143	408	937	1069		
		kg	21	21.5	22.5	29.5	32	46	51	65	185	425	485		
1.5 to 8.5 psi (0.1 to 0.6 bar)	Height H	24.6" (625 mm)					27.6" (700 mm)			29.7" (755 mm)	44.1" (1120 mm)	49.6" (1260 mm)			
	Actuator	ØD = 8.9" (225 mm) · A = 25 in ² (160 cm ²) ²⁾					ØD = 11.2" (285 mm) A = 50 in ² (320 cm ²)			ØD = 15.4" (390 mm) A = 100 in ² (640 cm ²) ²⁾					
	Weight ³⁾	lb	35.3	36.3	38.5	54	60	111	113	143	408	937	1069		
		kg	16	16.5	17.5	24.5	27	46	51	65	185	425	485		
3 to 15 psi (0.2 to 1 bar)	Height H	24.6" (625 mm)					27.6" (700 mm)			29.1" (740 mm)	44.1" (1120 mm)	49.6" (1260 mm)			
	Actuator	ØD = 8.9" (225 mm) · A = 25 in ² (160 cm ²) ²⁾								ØD = 15.4" (390 mm) A = 100 in ² (640 cm ²)					
	Weight ³⁾	lb	35	36	39	54	60	93	104	135	408	937	1069		
		kg	16	16.5	17.5	24.5	27	42	47	61	185	425	485		
7 to 20 psi (0.5 to 1.5 bar)	Height H	24.6" (625 mm)					30" (700 mm)			29.7" (755 mm)	42.1" (1070 mm)	47.6" (1210 mm)			
	Actuator	ØD = 8.9" (225 mm) · A = 25 in ² (160 cm ²) ²⁾								ØD = 11.2" (285 mm) A = 50 in ² (320 cm ²)					
	Weight ³⁾	lb	35	36	39	54	60	93	104	135	386	915	1047		
		kg	16	16.5	17.5	24.5	27	42	47	61	175	415	475		
15 to 35 psi (1 to 2.5 bar)	Height H	24" (610 mm)					27.6" (700 mm)			29.7" (755 mm)	42.1" (1070 mm)	47.6" (1210 mm)			
	Actuator	ØD = 8.9" (225 mm) · A = 25 in ² (160 cm ²)													
	Weight ³⁾	lb	35	36	38	54	59	93	104	135	386	915	1047		
		kg	16	16.5	17.5	24.5	27	42	47	61	175	415	475		
30 to 75 psi (2 to 5 bar)	Height H	24.6" (625 mm)					27.6" (700 mm)			29.7" (755 mm)	42.1" (1070 mm)	47.6" (1210 mm)			
	Actuator	ØD = 6.7" (170 mm) · A = 12 in ² (80 cm ²)								ØD = 8.9" (225 mm) A = 25 in ² (160 cm ²)					
	Weight ³⁾	lb	35	36	39	54	60	93	104	135	375	904	1036		
		kg	16	16.5	17.5	24.5	27	42	47	61	170	410	470		
65 to 145 psi (4.5 to 10 bar)	Height H	24.6" (625 mm)					27.6" (700 mm)			29.7" (755 mm)	On request				
	Actuator	ØD = 6.7" (170 mm) · A = 12 in ² (80 cm ²)													
	Weight ³⁾	lb	35.3	36.3	38.5	54	59.5	92.6	103.6	134.5					
		kg	16	16.5	17.5	24.5	27	42	47	61					

¹⁾ Optionally with actuator 100 in² (640 cm²)

²⁾ Optionally with actuator 50 in² (320 cm²)

³⁾ The weight applies to the version with the material specifications A126B. Add +10 % to all other materials.

Dimensional drawing · Type 42-20 and Type 42-25 · Balanced by a diaphragm

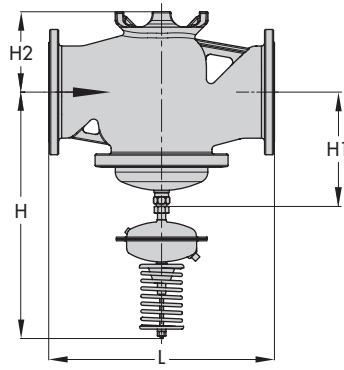

Type 42-20 and Type 42-25 · Type 2422 Valve balanced by a diaphragm with Type 2420/2425 Actuator

Type 42-25 with two diaphragms: Add approx. 2.2" (55 mm) to the total height H.

Type 2422 Valve · Balanced by a diaphragm

Fig. 8: Dimensions in mm · Valve balanced by a diaphragm

Table 5: Dimensions and weights for Type 42-20 and Type 42-25 · Balanced by a diaphragm

Valve size	NPS	2½	3	4	6	8	10
	DN	65	80	100	150	200	250
Length L	Class 125/150	10.9" (276 mm)	11.75" (298 mm)	13.9" (352 mm)	17.75" (451 mm)	21.4" (543 mm)	26.5" (673 mm)
	Class 300	11.5" (292 mm)	12.5" (318 mm)	14.5" (368 mm)	18.6" (473 mm)	22.4" (568 mm)	27.9" (708 mm)
Height H1 ¹⁾		14" (355 mm)		14.8" (375 mm)	-		
Height H2		3.9" (98 mm)		4.6" (118 mm)	6.9" (175 mm)	10.2" (260 mm)	
Height H		22.6" (575 mm)		23.4" (595 mm)	29.3" (745 mm)	37.8" (960 mm)	
Weight, approx.	42-25	93 lb (42 kg)	104 lb (47 kg)	121 lb (55 kg)	209 lb (95 kg)	551 lb (250 kg)	595 lb (270 kg)
	42-20	84 lb (38 kg)	95 lb (43 kg)	112 lb (51 kg)	-		

¹⁾ Type 42-20

Ordering text

Type 42-20 and Type 42-25 Differential Pressure Regulator

NPS ... (DN ...), valve balanced by a bellows/diaphragm

Class ..., body material ...

Set point or set point range ... psi (bar)

Optionally, accessories ...

Optionally, special version

Specifications subject to change without notice

