

Media 5 · Indicator 160Ø · PN 50

Application

Transmitter for measuring and indicating the differential pressure or measured variables derived from it · Suitable for gases or liquids · Measuring ranges between 0 to 40 and 0 to 3600 mbar · Static pressures up to 50 bar · Optionally with limit switch including three inductive alarm contacts or with 4 to 20 mA current output



Measurement tasks

- Liquid level measurement in pressure tanks, especially for cryogenic gases
- Differential pressure measurement between flow and return flow pipe
- Pressure drop measurement across valves and filters
- Flow rate measurement according to the differential pressure method

Special features

- Suitable for liquids, gases or vapors
- Overloadable on one side up to the perm. static pressure
- Suitable for field installation (degree of protection IP 54/ IP 65) and panel mounting
- Zero adjustment from the front
- Adjustment of measuring span 1:2
- Housing of indicating unit with burst protection
- Limit switch and current output easy to retrofit
- Directly connectable valve block (optional) with connection to monitor the tank pressure and with connection for pressure switch

Versions (Fig. 1)

Media 5 consisting of:
Indicator NG 160 with pointer mechanism · dp cell made of CW617N (brass) or stainless steel, PN 50 · Free of oil and grease for oxygen · Measuring ranges from 40 to 3600 mbar ECO measuring diaphragm · Zero adjustment at the front
Process connections G 3/8 A

Optionally available with accessories:

- Dials
- Scale 0 to 100 % linear or square root graduation, dial plates according to DIN EN 837-3, detachable dial plates for different media, special dial plates
- Valve block which can be directly mounted onto Media 5 devices
- Screw fittings
- Pressure gauges
- Inductive limit switch with max. three alarm contacts A1/ A2/A3 (proximity switches) · Version for hazardous locations
- 4 to 20 mA current output

Special versions on request



Media 5 with 4 to 20 mA current output (optional)



Media 5 with limit switch (optional)

Fig. 1: Media 5, indicator Ø 160 mm with attached valve block and pressure gauge for operating pressure

Principle of operation (Fig. 2)

Media 5 with limit switch (optional)

The dp cell works according to the deflection method and contains an ECO measuring diaphragm (1.5) which is designed to handle measuring spans from 40 to 3600 mbar. The diaphragm stem (1.7) is connected to a lever (1.8) and is supported and guided by the range springs. The lever leads the deflection of the measuring system out of the pressure chamber. The pressure chamber is sealed by a flexible disk (1.9). The range springs, which are connected to the housing, and the diaphragm ensure that the position of the lever is independent of the static pressure. The dp cell can be overloaded on one side as the measuring diaphragm flexes against the housing wall whenever the measured values are out of range.

The differential pressure $\Delta p = p_1 - p_2$ creates a force at the measuring diaphragm (1.5), which is opposed by the range springs (1.4). The movement of the measuring diaphragm and lever (1.8), which is proportional to the differential pressure, is transferred by the adjustable transmission element (2.1) and pointer mechanism equipped with jewel bearings (2.2) to the pointer (2.4).

The range springs (1.4) installed in the dp cell determine the upper and lower limit of each measuring span (measuring span limit) of the device. The span can be continuously adjusted within these limits in the ratio of 1:2 at the transmission element. This adjustment changes the transmission ratio between the lever (1.8) and the pointer mechanism (2.2).

Depending on the direction of action, the shaft of measuring unit (3.1) bears the metal tags (3.2) and moves them into the limit switch with the two alarm contacts (proximity switches) A1 and A2 (3.3).

If the metal tag enters the inductive field of the associated proximity switch, it assumes a high resistance (contact open). If the metal tag leaves the inductive field, it assumes a low resistance (contact closed). This function is similar to that of a mechanical-type switching contact.

The proximity switches can be adjusted independently from one another. They provide a signal when the differential pressure either increases or decreases and the metal tags enter or leave the inductive field of the switch. The proximity switches have a LED indicator, allowing the limit values to be easily adjusted on site.

Isolating switch amplifiers conforming to EN 60947-5-6 must be connected in the output circuit of the inductive alarm contacts A1/A2 to ensure they meet the operational requirements of any connected control and signaling equipment.

Media 5 with current output (optional)

The 4 to 20 mA current output unit upgrades the analog reading of the Media 5 by issuing a 4 to 20 mA current signal which can be used for electric signal transmission and further processing. The measuring signal, which is proportional to the pointer deflection, is automatically calibrated with the mechanical reading. As a result, a deflection of 270° corresponds to an output signal of 20 mA.

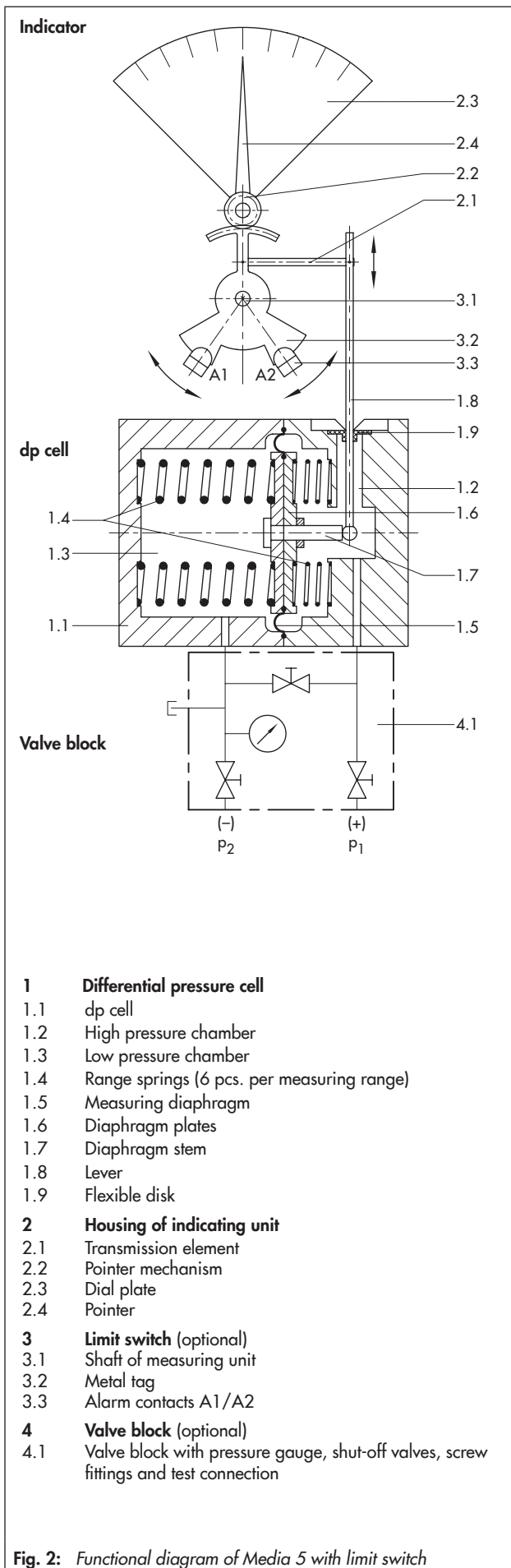

Fig. 2: Functional diagram of Media 5 with limit switch

Table 1: Technical data · All pressure stated as gauge pressure

Media 5 Differential Pressure and Flow Meter											
Measuring range in mbar	0 to 60	0 to 100	0 to 160	0 to 250	0 to 400	0 to 600	0 to 1000	0 to 1600	0 to 2500	0 to 3600	
Measuring span in mbar	min. max.	40 to 60	50 to 100	80 to 160	125 to 250	200 to 400	300 to 600	500 to 1000	800 to 1600	1250 to 2500	1800 to 3600
Nominal pressure	PN 50, overloadable on one side up to 50 bar										
Indicator	Ø160 mm										
Characteristic	Reading linear to the differential pressure										
Deviation from terminal-based linearity	<±2.5 %	<±1.6 % including hysteresis									
Sensitivity	<±0.5 %	<±0.25 %									
Effect of static pressure	<0.03 %/1 bar										
Degree of protection according to DIN EN 60529	IP 54										
Weight	Approx. 3 kg without valve block Approx. 5 kg with valve block										
Limit switch (optional)											
Limit contacts	Max. 3 alarm contacts A1, A2 and A3 with inductive pick-up and LED according to EN 60947-5-6										
Control circuit	Values corresponding to connected isolating switch amplifier according to EN 60947-5-6, e.g. KFA6-SR2-Ex2.W										
Proximity switch	SJ3.5-N-LED, for hazardous areas according to PTB 99 ATEX 2219X										
Switching accuracy	<±2 %										
Dead band, approx.	<0.6 %										
4 to 20 mA current output (optional)											
Version	Magneto-resistive measuring system										
Supply voltage U_B	12 to 36 V (DC)										
Output signal	4 to 20 mA, two-wire system										
Perm. load R_B in Ω	$R_B = (U_B - 12 \text{ V})/0.020 \text{ A}$ ($R \leq 600 \Omega$ at 24 V and 20 mA)										
Power consumption	103 mW										
Settings	Zero calibration Span calibration Characteristic selection Test function										
Characteristic	Output and reading linear or root-extracting depending on installed flow characteristic Characteristic set at the factory										
Deviation from terminal-based linearity	<±0.2 %, related to 270° measuring span										
Sensitivity	<±0.05 %, related to 270° measuring span										
Effect of ambient temperature in the range from -40 to +80 °C	<0.1 %/10 K for zero and span										
Ambient conditions											
Permissible ambient temperature range	-40 to +80 °C										
Perm. storage temperature range	-40 to +100 °C										
Use of Media 5 with gaseous oxygen											
Max. oxygen pressure	50 bar										
Perm. ambient temperature range	-40 to +60 °C										

Note

- All pressure stated as gauge pressure
- All errors and deviations are specified in % of the adjusted measuring span.
- The Media 5 Differential Pressure and Flow Meter without limit switches may be used to measure flammable gases and liquids in which hazardous area conditions of Zone 0 are to be expected. The relevant regulations on the measurement of flammable gases and liquids of Zone 0 must be observed.
- Oxygen service: when the device is used for oxygen service, make sure that the dp cell and any SAMSON accessories (e.g. valve block) only come into contact with gaseous oxygen.
- Refer to ► EB 9519 for more details.

Table 2: Materials

Media 5 Differential Pressure and Flow Meter	
dp cell	CW617N (brass) or CrNi steel
Measuring diaphragm and seals	ECO ¹⁾
Springs, diaphragm plates and functional parts, lever	CrNi steel
Housing of indicating unit	Polycarbonate

¹⁾ Other on request

Accessories

Accessories for additional functions are available for Media 5: **limit switch** (alarm contacts A1, A2 und A3) or **4 to 20 mA current output**. The accessories can be fitted before delivery or retrofitted on a Media 5 device already installed.

Both options (limit switch **or** current output) are fitted in the housing of the indicating unit in place of the cover plate. The housing must be opened to operate and adjust them.

Limit switch

A1 = First min. contact · A2 = Second min. contact · A3 = Max. contact

Proximity switches with normally closed function
Metal tag outside the inductive field
 Switching signal "ON" (L signal of the proximity switch)
 Function: contact closed or output effectively conducting, low resistance (undamped), power consumption ≥3 mA

Metal tag inside the inductive field
 Switching signal "OFF" (0 signal of the proximity switch)
 Function: contact open or output effectively non-conducting, high resistance (damped), power consumption ≥1 mA

Fig. 3: Limit switch with three alarm contacts in the housing of the indicating unit

Table 3: Functions for two alarm contacts A1 and A2

Overview of functions	Adjustment ranges			
	Min. contact (gas withdrawal)		Max. contact (tank filling)	
Proximity switch for ...				
Alarm contacts	A1	A2	A1	A2
Metal tag inside	1.2	2.1	1.1	2.2
Metal tag outside	1.1	2.2	1.2	2.1

Table 4: Functions for three alarm contacts A1, A2, and A3

Overview of functions	Adjustment ranges		
	Two min. contacts (gas withdrawal)		One max. contact (tank filling)
Proximity switch for ...			
Alarm contacts	A1	A2	A3
Activation when metal tag inside field	1.2	2.1	2.2

Switching points

Min. contact with decreasing reading
 Max. contact with increasing reading

Table 5: Technical data for limit switch in type of protection
Ex ia IIC T6 (PTB 99 ATEX 2219 X)

Circuit	Type 1			Type 2		
	U _i	16 V			16 V	
I _i	25 mA			25 mA		
P _i	34 mW			64 mW		
C _i	50 nF			50 nF		
L _i	250 µH			250 µH		
Temperature class	T6	T5	T4	T6	T5	T4
	73 °C	88 °C	100 °C	66 °C	81 °C	100 °C

Electrical connection of alarm contacts

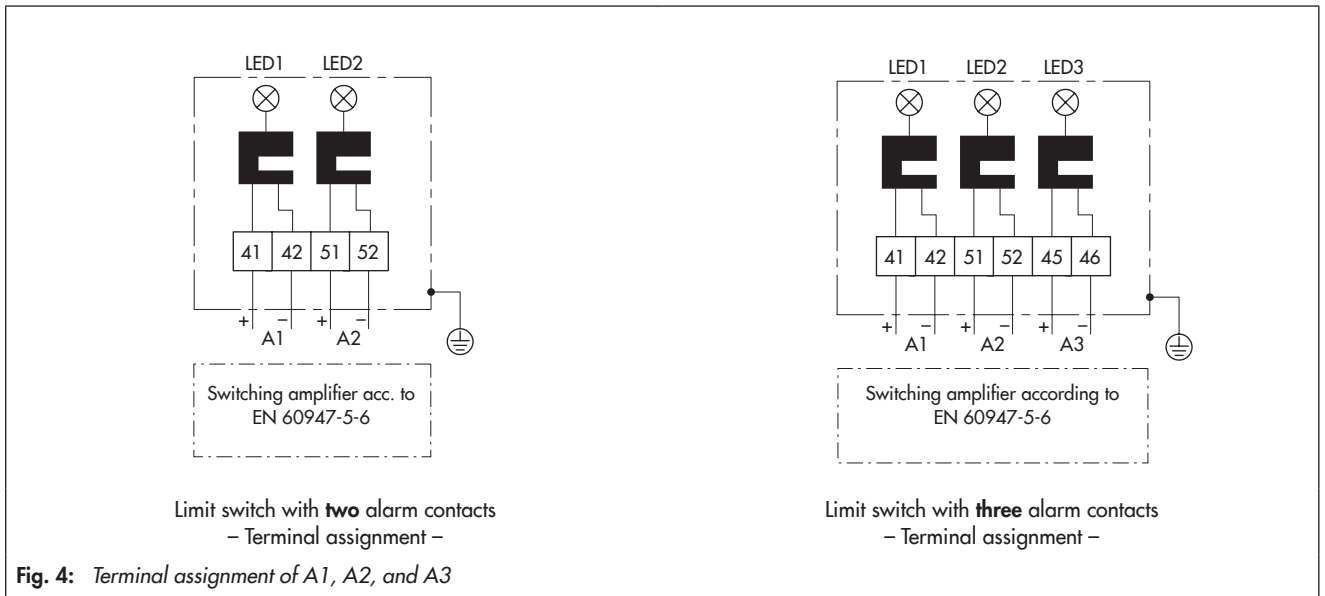

4 to 20 mA current output

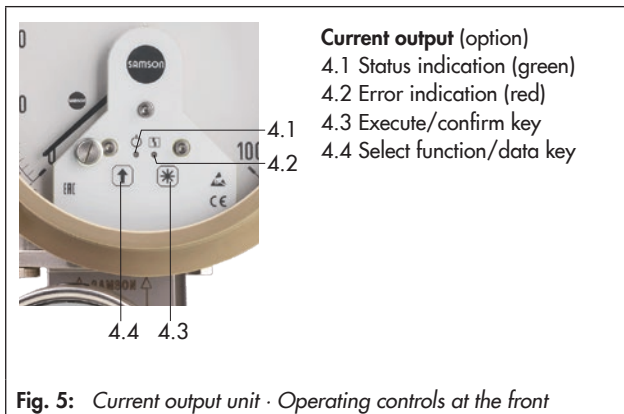

Functions (selected at the front)

Zero calibration

Zero calibration in pointer range from approx. -5° to 20° .

Span calibration

The measuring span can be calibrated continuously in the pointer range $>130^\circ$ without affecting zero or the measuring accuracy. The pointer position corresponds to the end point with 20 mA output signal. As a result, the end points can easily be adjusted especially for various media.

Characteristic selection

A linear and a root-extracting characteristic (filling level and flow measurement) can be adjusted. A third characteristic can be saved at the factory before delivery.

4 mA/20 mA test signal

To calibrate the assessment unit, 4 and 20 mA test signals are issued.

Supply voltage

To operate the unit, a transmitter supply voltage of $U_B = 12$ to 36 V is required for the 4 to 20 mA measuring circuit. Both the 4 to 20 mA measuring signal and the required supply voltage for the two-wire transmitter are transmitted by the same pair of wires.

For this purpose, the SAMSON Type 5024-1 Power Supply and Indicator Unit can be used. It supplies the voltage and indicates the measuring signal.

Measuring signal connection

The current output unit is designed as a two-wire system. It is connected to the terminal board over two cage clamp terminals.

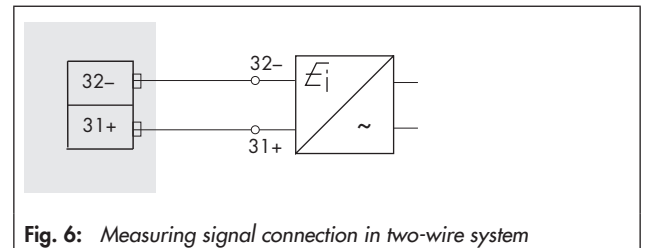

A Media 5 device can be fitted upon delivery with a 4 to 20 mA current output. A retrofit in already installed devices (even former device model from 2001 onwards) is possible on site.

Installation

Pipe mounting with mounting part and clamp for attachment to a vertical or horizontal 2" pipe.

Wall/panel mounting · Using two M8 tapped holes located in the valve block or at the back of the dp cell

Panel mounting optionally with M4 cap screws, M4 thread in the control panel or hex bolts with M4 hex nuts.

Process medium connection: Tapped hole ISO 228 G 3/8

Dimensions in mm

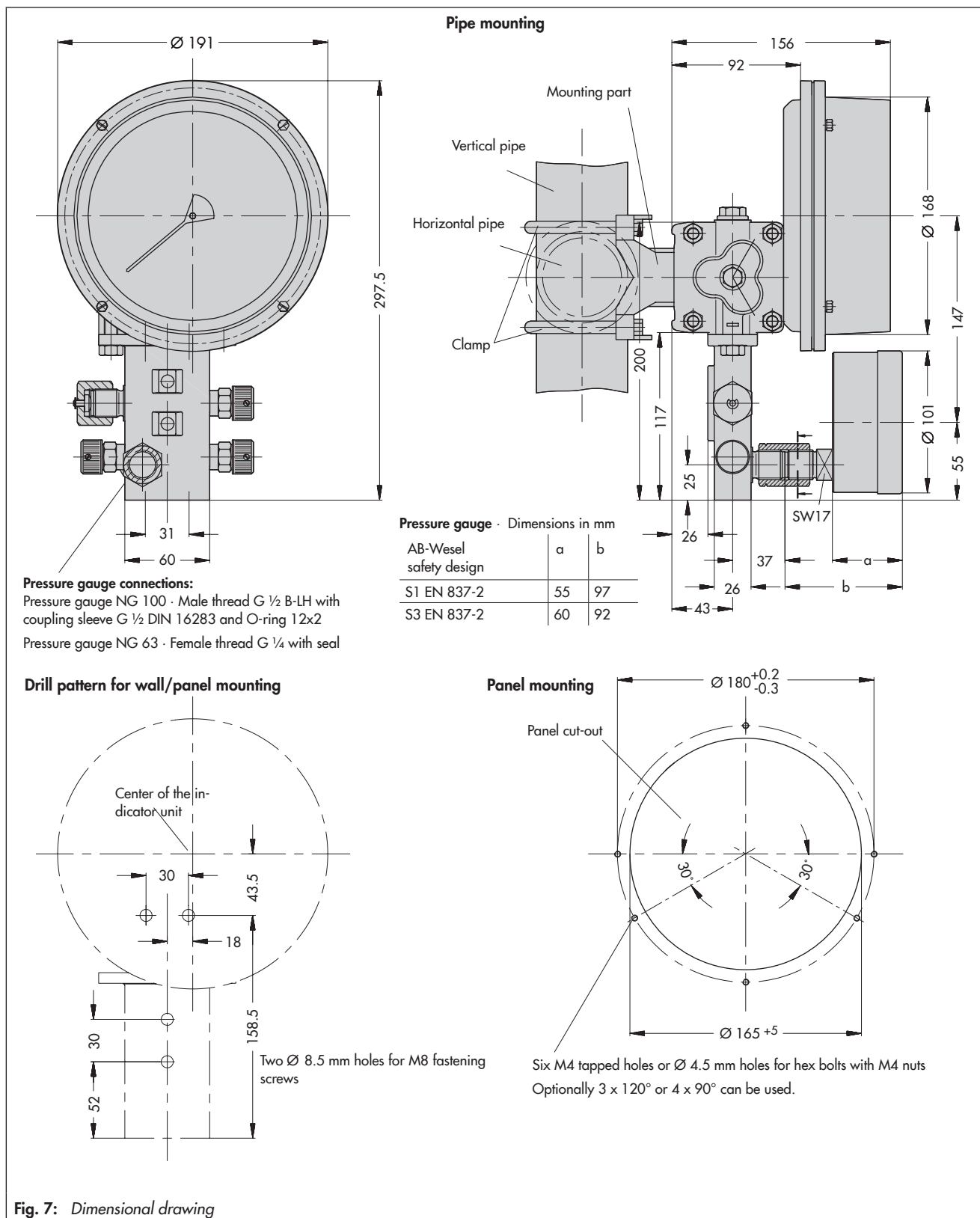

Fig. 7: Dimensional drawing

Table 6: Device configuration with order numbers

Complete the order number with the order codes for the selected options

Order no.	Type 5005A-
Device	Media 5, dp cell made of CW617N (brass)	0					
	Media 5, dp cell made of 1.4581 (stainless steel)	1					
Version	Standard version		0				
	Free of oil and grease for oxygen (SAMSON Standard 1.34-2, sheet 1)		1				
Measuring range (measuring span)	0 to 60 mbar/min. 40 mbar · max. 60 mbar			0	2		
	0 to 100 mbar/min. 50 mbar · max. 100 mbar			0	3		
	0 to 160 mbar/min. 80 mbar · max. 160 mbar			0	4		
	0 to 250 mbar/min. 125 mbar · max. 250 mbar			0	5		
	0 to 400 mbar/min. 200 mbar · max. 400 mbar			0	6		
	0 to 600 mbar/min. 300 mbar · max. 600 mbar			0	7		
	0 to 1000 mbar/min. 500 mbar · max. 1000 mbar			2	0		
	0 to 1600 mbar/min. 800 mbar · max. 1600 mbar			2	1		
	0 to 2500 mbar/min. 1250 mbar · max. 2500 mbar			2	2		
	0 to 3600 mbar/min. 1800 mbar · max. 3600 mbar			2	3		
	Zero screw	With zero screw (standard version)					0
With concealed zero screw						1	
Options	Limit switch ¹⁾	Without alarm contacts					0
		With two inductive alarm contacts SC 3,5-NO-BU					2
		With three inductive alarm contacts SC 3,5-NO-BU					3
		With three-wire alarm contacts, SB 3,5-E2					6
		With two inductive alarm contacts, SJ 3,5-SN					7
		4 to 20 mA current output					

¹⁾ When delivered with installed limit contacts. Default: min. contact 22°, max. contact 93°

Additionally required ordering specifications

Measured value setting ¹⁾ Unit

Adjusted to 0 to ... mbar

¹⁾ With default settings of measured value: 0 to max. measured value

Additionally required ordering specifications (only for limit switch)

		Alarm contacts					
		Contact A1		Contact A2		Contact A3	
Min. contacts = Value decreasing	Metal tag is ...	inside	outside	inside	outside	inside	outside
Max. contacts = Value increasing	When measured value ...	Increasing/decreasing	Increasing/decreasing	Increasing/decreasing	Increasing/decreasing	Increasing/decreasing	Increasing/decreasing
For switching value mbar		... mbar		... mbar	

Additionally required ordering specifications (only for 4 to 20 mA current output)

Reading adjusted to: 4 to 20 mA or 0° to ...° (angle) or end point of medium (with special dial plates): e.g. N₂, O₂, Ar, etc.

Characteristic: Linear, root-extracting or default setting (according to specification, see T 9520-9)

Accessories ▶ T 9555 · Dial plates ▶ T 9545

Certificates and approvals

- CE compliance
- Registered by the metrological service of the federal agency for technical regulation and metrology for use in the Russian Federation
- Oxygen service, test report No. 2012/R249a based on DIN EN ISO 7291

Ordering text

Media 5 Differential Pressure and Flow Meter

Order no.: Type 5005A-

Special version ...

Specifications subject to change without notice



SAMSON AG · MESS- UND REGELTECHNIK
Weismüllerstraße 3 · 60314 Frankfurt am Main, Germany
Phone: +49 69 4009-0 · Fax: +49 69 4009-1507
samson@samson.de · www.samson.de

T 9519 EN

2016-06-23 · English