

# PyroPure Pure Steam Condensing System

## The Mueller PyroPure P4000 Series Advantage

The Mueller PyroPure pure steam condensing systems are designed for use by companies in the pharmaceutical and biotechnological industries who want to use their pure steam generating systems for the production of WFI quality distillate as well as WFI quality pure steam. When used with a Mueller PyroPure pure steam generator or when fed WFI quality pure steam from another source, the water produced will be pyrogen free and will meet or exceed the latest specifications of the USP for water-for-injection (WFI). The condensing system may be provided integral to a Mueller PyroPure pure steam generator skid or as a separate stand-alone skid. The stand-alone design for the condensing system allows it to be installed adjacent to a pure steam generator or located remotely at the point of use.

Pure steam enters the system and flows into the shell side of the condenser for the condensation and subcooling to the required product temperature. Coolant such as chilled water or a glycol solution is used on the tube side of the condenser for cooling. The final product is measured for conductivity to ensure compliance with specifications.

Control of the condensing system is accomplished by a single control loop. The loop monitors the product temperature and manipulates a coolant control valve to maintain the specified product temperature.

## Simple Design, Reliable Operation

- WFI condensers have removable tube bundles for easy cleaning and inspection of product contact surfaces.
- All maintenance, including replacement of critical components, can be performed with only 24" of space on all sides (including the top) of the equipment.
- All components are fully drainable.
- Minimal instrumentation is required for operation of the equipment. Only one control loop is needed which minimizes the calibration required as well as the potential for downtime.
- All elastomers in contact with pure steam and product are provided with USP Class VI certifications.
- ASME-BPE certified fittings are used throughout.
- All product contact surfaces are manufactured from 316/316L stainless steel polished to 20 Ra maximum and electropolished.



## System Components

**Condenser.** Mueller PyroPure condensers have a double-tubesheet design, providing users with efficient heat exchange while ensuring pure vapor and distillate never come into contact with feedwater and coolant. To facilitate maintenance, all PyroPure condensers are mounted at an angle to allow full drainage of the pure distillate through the distillate outlet port installed at the vessel's lowest point. The condenser is designed to allow the removal of the U-tube bundle for easier inspection of critical pure distillate contact surfaces.

**Controls.** An Allen Bradley PLC with an Allen Bradley operator interface mounted in a NEMA rated panel is the standard control system. Ethernet is provided to facilitate communication with adjacent equipment or data archiving systems. Mueller can also provide other Allen Bradley control components, as well as control systems from Siemens and Mitsubishi. Control and electrical panels are supplied with a UL 508a label.

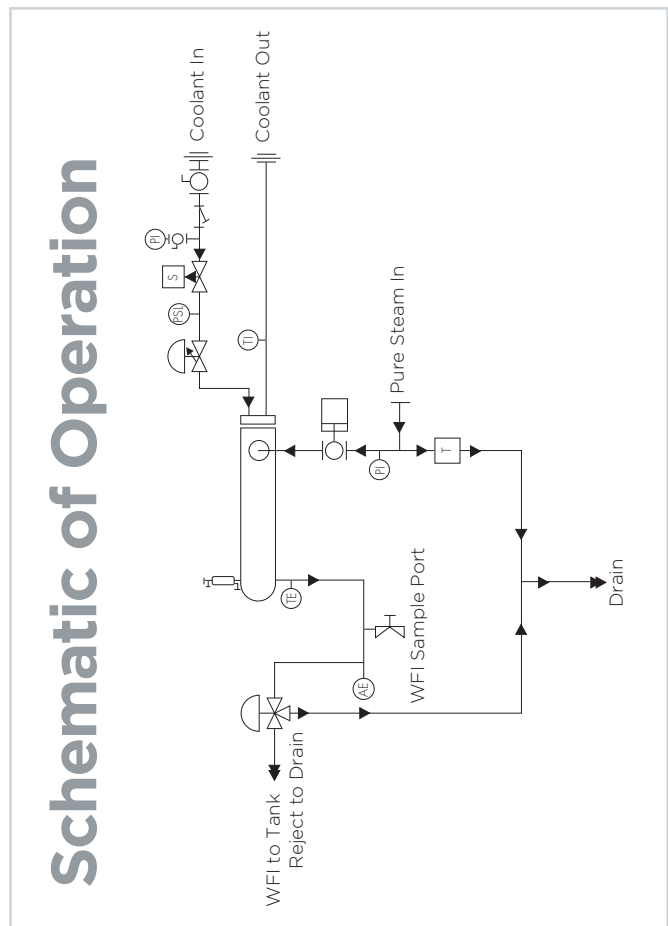

## Specifications

Model Numbers	P4001	P4002	P4003	P4004
Capacity, gph (lph) <sup>2</sup>	25 (95)	50 (189)	100 (379)	150 (568)
Pure Steam Inlet	1.5" TC	1.5" TC	1.5" TC	2" TC
Coolant Inlet/Outlet	.75" FNPT	.75" FNPT	1" FNPT	1" FNPT
Distillate Outlet	1.5" TC	1.5" TC	1.5" TC	1.5" TC
Instrument Air	.25" FNPT	.25" FNPT	.25" FNPT	.25" FNPT
Pure Steam, lb/hr (kg/hr)	202 (92)	403 (183)	807 (366)	1,210 (549)
Coolant, gph (lph) <sup>2</sup>	241 (912)	486 (1,840)	978 (3,702)	1,470 (5,565)
Electrical Service (Standard) <sup>3</sup>	115 VAC, 1phase, 50/60 Hz. (Other voltages available upon request)			
Height <sup>4</sup>	106" (269 cm)	108" (274 cm)	111" (282 cm)	111" (282 cm)
Width <sup>4</sup>	55" (140 cm)	55" (140 cm)	55" (140 cm)	55" (140 cm)
Depth <sup>4</sup>	37.5" (95 cm)	37.5" (95 cm)	37.5" (95 cm)	37.5" (95 cm)
Distillate Outlet Height <sup>4</sup>	85" (216 cm)	85" (216 cm)	85" (216 cm)	85" (216 cm)

<sup>1</sup> Pure Steam 15–90 psig (1.0–6.2 barg) dry and saturated (capacity based on 45 psig, 3.1 barg).

<sup>2</sup> Coolant water at 32°F to 100°F (0°C to 38°C) at 40 psig (2.8 barg) (flow rates based upon a distillate outlet temperature of 190°F [88°C] and cooling water inlet temperature of 60°F [16°C]).

<sup>3</sup> Other electrical services must be specified at time of order.

<sup>4</sup> Dimensions for stand-alone system only. For systems integral to a pre steam generator, dimensions will vary based on the model of pure steam generator used. Approximate operating/shipping weight is 2,500lb (1,134 kg).