



High impact tank cleaning machine

Series 5TB

Series 5TB

The 5TB has firmly established itself, above all in the pharmaceutical, food and beverage industries because of its hygienic design and high quality. The especially strong solid jets produce an extremely high degree of effectiveness, while the gear-controlled rotation ensures high levels of efficiency. This series is suitable for high pressures and temperatures.



To see video

Scan the QR-code
or go to:
www.lechlerusa.com



Max. Tank diameter [ft]

0

15

30

45

60



Materials

Stainless steel AISI 316L, PTFE, PEEK, Zirconium oxide, EPDM, 32 RA surface finish is included with every material



Max. temperature

203°F/ 95°C
248°F/ 120°C ATEX version



Recommended operating pressure

75 psi



Installation

Operates in every direction



Filtration

Line strainer with a mesh size of 0.2 mm/80 Mesh



Bearing

Ball bearing



Weight

8.8 lbs



Rotation monitoring sensor

Sensor compatible
Info: see page 68

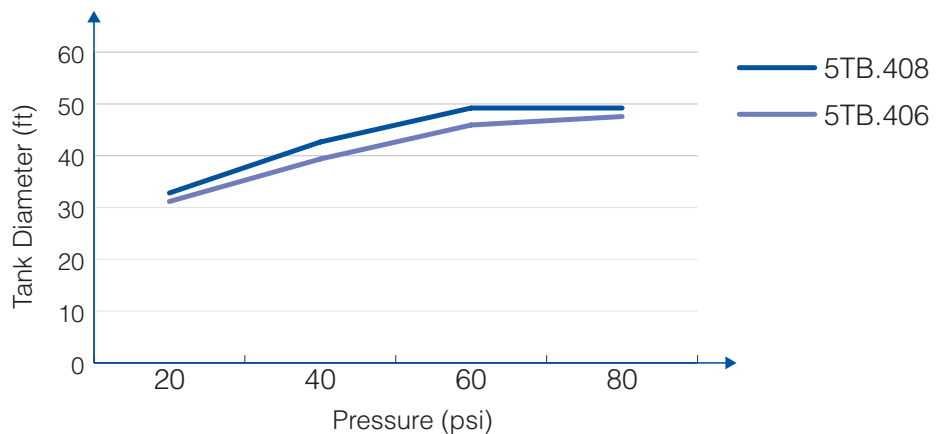

Overview of the tank diameter, depending upon the pressure of series 5TB



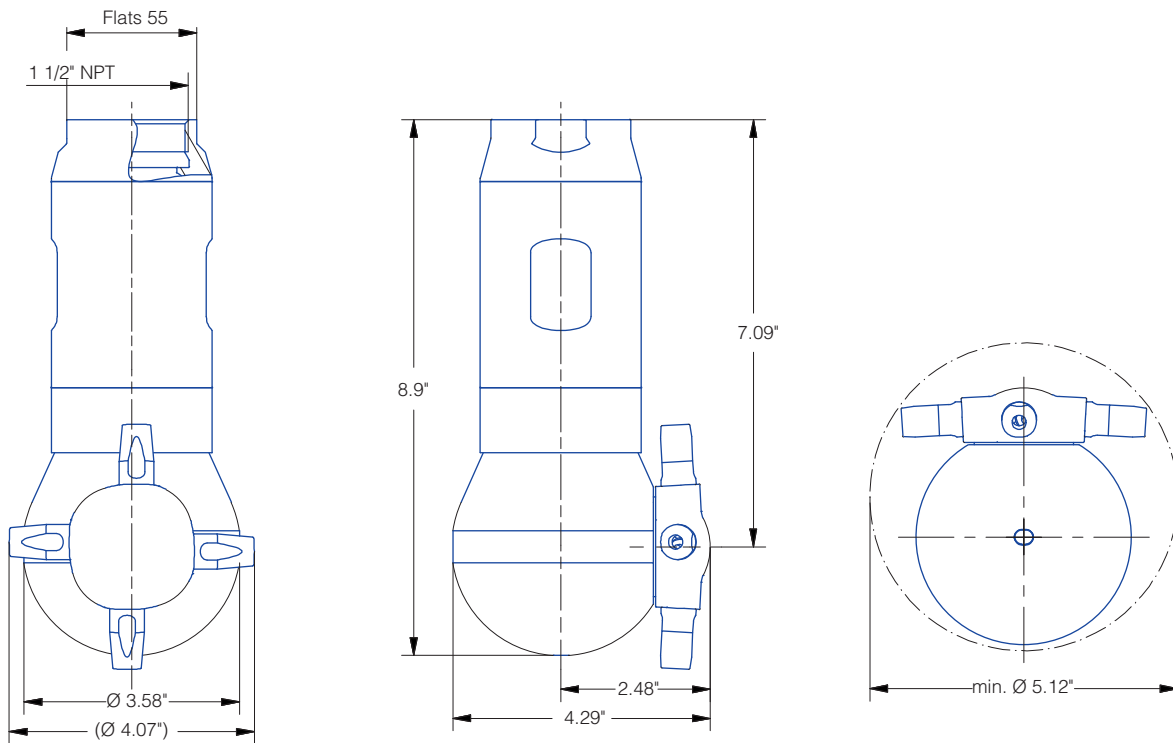

Spray angle	Ordering no.	Free Passage (in.)	Number, Ø Nozzles [mm]	Flow Rate (Gallons Per Minute)					Max pressure (psi)	Max. tank diameter [ft]
				liters per minute 2 bar	30 psi	40 psi	75 psi	145 psi		
360°	5TB. 406. 1Y. BS	.236	4 x 6.0	107	29	33	45	63	362	46
	5TB. 407. 1Y. BS	.236	4 x 7.0	135	36	42	57	80	362	46
	5TB. 408. 1Y. BS	.236	4 x 8.0	165	44	51	70	98	362	49

The maximum tank diameter shown above applies for the recommended operating pressure and is indicative only. The cleaning result is also affected by the type of soiling.

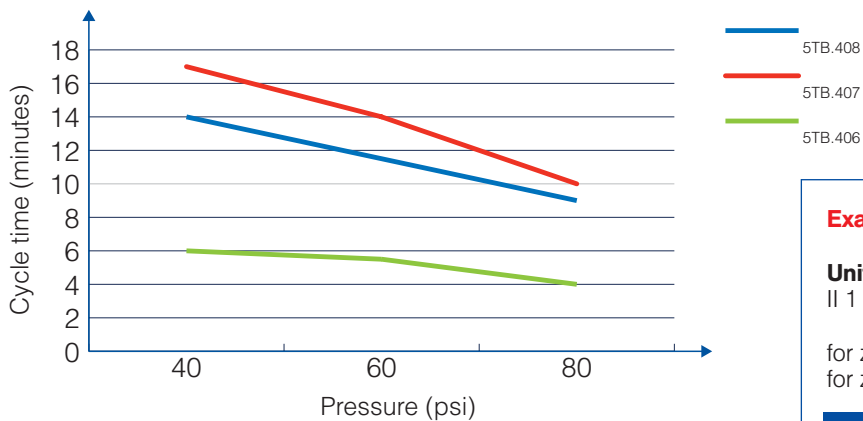

Cycle time depending on pressure of series 5TB

Example of ordering ATEX approval

Unit group / category / zones:
II 1 GD c IIB TX 120 °C +4 °C ≤ Ta ≤ +90 °C

for zone 0, 1, 2 (gas atmosphere)
for zone 20, 21, 22 (dust atmosphere)



Example of ordering: Type + Connection = Ordering no.
of ordering: 5TB.406.1Y.XX.EX + BL = 5TB.406.1Y.BL.EX

