

Continuous Duty Vacuum **POWERHOUSE** CONTINUOUS DUTY VACUUM DS2520

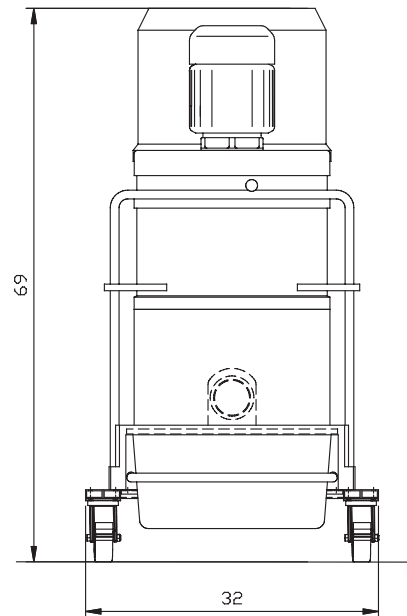

POWERHOUSE SERIES

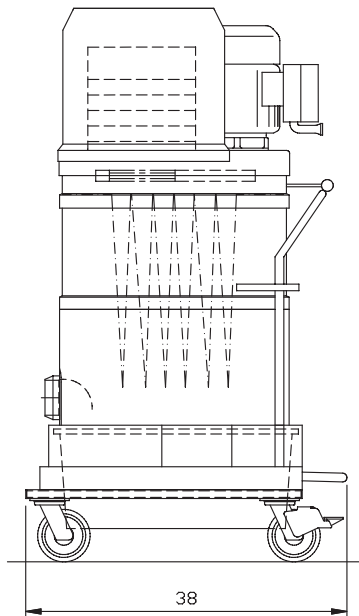

DS2520 Standard Specifications

- 7.5 HP TEFC Motor, 208-230, 460 Volt, 3-Phase, 60 Hz, 17, 8 Amps
- Motor Starter - Class 10 Motor Overload Protection
- 48 ft² MicroClean Filter with Manual Shaker System
- 2.75" (70mm) Inlet Connection with Aluminum Cast Deflector
- 2 Multi-Stage Centrifugal High Performance Turbines w/ Relief Valve
- 24 Gallon, Foot Lever Actuated Dustpan
- Counterbalanced Base with 6" (152mm) Heavy Duty Double Casters
- Fiberglass Reinforced Thermoplastic Modular Housing
- Also Available - Dust Explosion Proof Motor & Switch, Class II, Group F & G



Base Price¹: DS 2520 - Call for Pricing

ADDER	DESCRIPTION
9853R	Motorized Filter Shaker with Switch, (3-Phase) ²
18630B	Reverse Pulse with Electronics & Pressure Gauge ²
25143	Minihelic for Filter Monitoring ²
34878	Retractable Grounding Reel with Stainless Steel Clamp ²
S	51 ft ² HEPA Filter with Minihelic for DS2 Series ¹
CON	Custom Steel Frame, Rubberized Inlet, and Additional Housing Spacer ¹

¹ PH1, ²ADD