

Continuous Duty Vacuum

WORKHORSE DS 1150 Silo



WORKHORSE SERIES



Manual blast gates, pneumatic blast gates, & rotary air locks are available as alternative discharge methods. Call for current pricing.

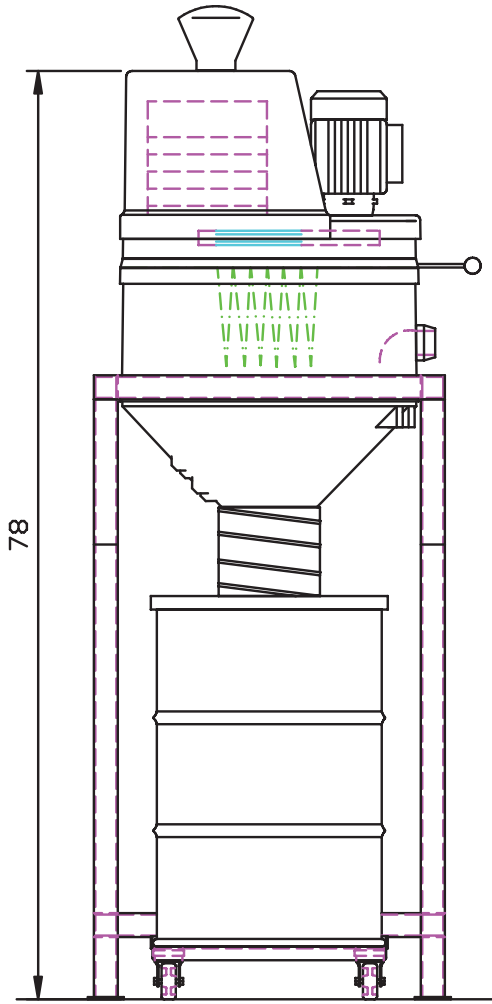
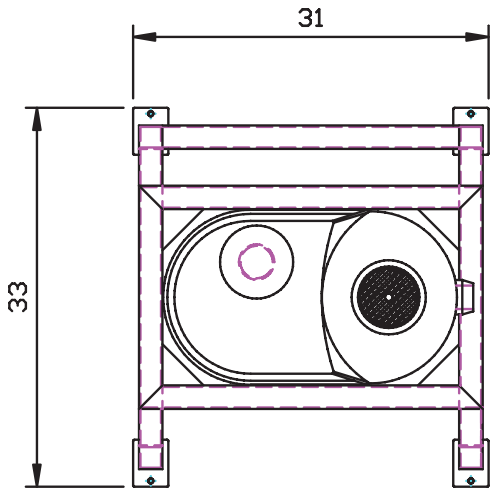

DS 1150 Silo Standard Specifications

- 3 HP TEFC Motor, 208-230, 460 Volt, 3-Phase, 60 Hz, 6,3 Amps
- Motor Starter - Class 10 Motor Overload Protection
- 13 ft² MicroClean Filter with Manual Shaker System
- 2" (50mm) Inlet Connection with Bronze Cast Deflector
- Multi-Stage Centrifugal High Performance Turbine w/Relief Valve
- Compression Cast Composite Modular Housing
- Carbon Impregnated, Anti-Static 10⁻⁶ Ohms
- 30 Gallon Capacity Drum
- Direct Drum Fill Lid & Drum Dolly with Heavy Duty 3" (76mm) Casters
- 2" x 2" (50mm x 50mm) Tubular Steel Stand

Base Price¹: DS 1150 Silo - Call for Pricing

ADDER	DESCRIPTION
A	28 ft ² MicroClean Filter with Manual Shaker ¹
B	40 ft ² HEPA Filter with Minihelic ¹
35230B	Active Charcoal Filter Assembly, 20 lbs. of media ²
9853B	Motorized Filter Shaker with Switch, 3 Phase ²
18630B	Reverse Pulse with Electronics & Pressure Gauge ²
25143	Minihelic for Filter Monitoring ²
34878	Retractable Grounding Reel with Stainless Steel Clamp ²
N	208/240 Volt, Single Phase ¹
Z	55 Gallon Capacity Drum & Fill Lid ¹

¹ - WHS, ² - ADD