

TOP VIEW

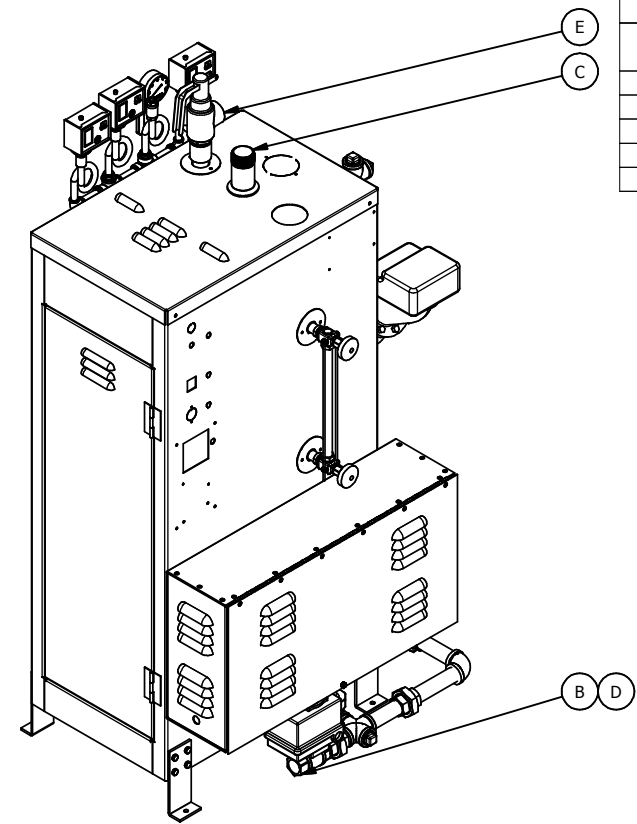

ISOMETRIC VIEW

CUSTOMER CONNECTIONS				
ITEM	DESCRIPTION	SIZE (100 PSI TRIM)	SIZE (15 PSI TRIM)	TYPE
A	FEED WATER INLET	1/2"	1/2"	N.P.T.
B	BLOWDOWN OUTLET	1"	1"	N.P.T.
C	STEAM OUTLET	1 1/2"	3"	N.P.T.
D	WATER COLUMN DRAIN	1"	1"	N.P.T.
E	SAFETY RELIEF VALVE	1 1/4"	1 1/4"	N.P.T.

EQUIPMENT SPECIFICATION CHART	
TYPE:	ELECTRIC
MAX ALLOWABLE WORKING PRESSURE:	100 PSI
BOILER OUTPUT:	368,560 BTU/HR
STEAM OUTPUT/MIN. SRV CAPACITY:	380 LBS/HR
NUMBER OF ELEMENTS (WATTAGE PER ELEMENT):	6 (18 kW)
WATER CAPACITY (OPERATING):	18 GAL.
APPROXIMATE DRY WEIGHT:	423 LBS.
APPROXIMATE OPERATING WEIGHT:	573 LBS.
APPROXIMATE SHIPPING WEIGHT:	700 LBS.
APPROXIMATE FLOODED WEIGHT:	656 LBS.

ELECTRICAL REQUIREMENTS	
VOLTAGE	OPERATING FLA
208/60/3	300 AMPS
240/60/3	260 AMPS
380/60/3	165 AMPS
480/60/3	130 AMPS
600/60/3	104 AMPS

NOTE: OPERATING FULL LOAD AMPERAGE (FLA) REFERS TO THE BOILER'S RATED CURRENT DRAW AT HIGH FIRE.

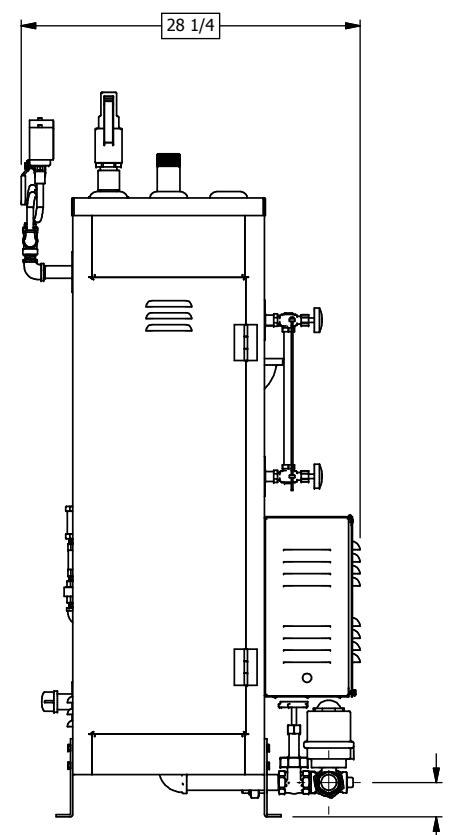

FRONT VIEW

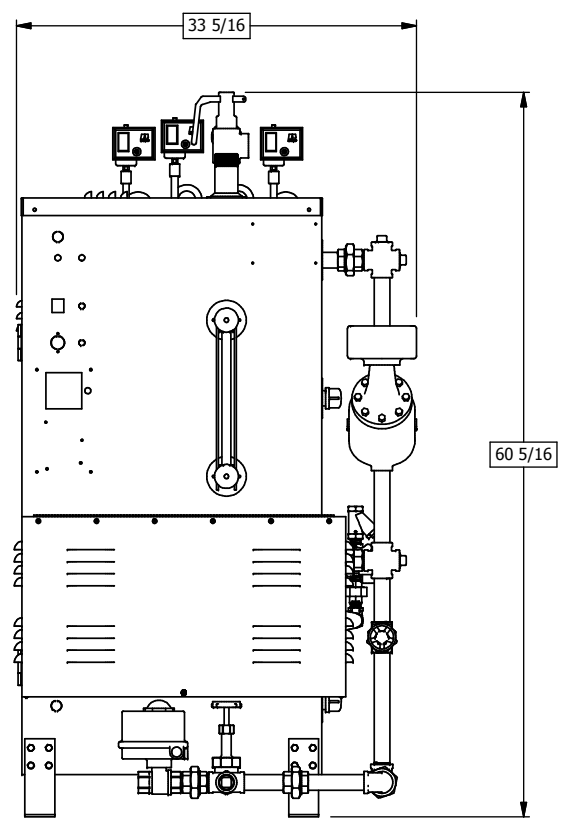

SIDE VIEW

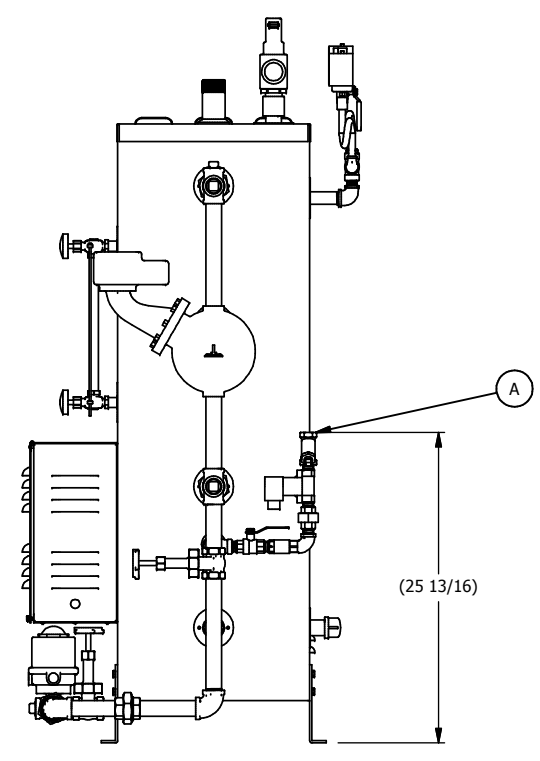

BACK VIEW

- NOTES:
- STEAM OUTPUT LB/HR: FROM 0 PSIG AT 212°F (0 KG/CM² AT 100°C)
  - ALL CLEARANCES ARE FACTORY RECOMMENDATIONS. CONSULT LOCAL JURISDICTION FOR EXACT CODE COMPLIANCE.
  - FULTON RECOMMENDS MINIMUM CLEARANCE OF 36" IN FRONT OF ELECTRICAL PANELS AND 24" AROUND SIDES OF BOILER.
  - PLEASE REFER TO THE O&M MANUAL FOR ADDITIONAL INFORMATION REGARDING CLEARANCES AND INSTALLATION INSTRUCTIONS.
  - ALL DIMENSIONS INSIDE ( ) DENOTE REFERENCE DIMENSIONS.
  - ALL DIMENSIONS INSIDE □ DENOTE OVERALL DIMENSIONS.
  - WE RESERVE THE RIGHT TO CHANGE SPECIFICATIONS AND/OR DIMENSIONS. ALL INFORMATION IS SUBJECT TO CHANGE BASED ON ADDITION OF ANY OPTIONAL EQUIPMENT AND/OR ACCESSORIES. PLEASE CONSULT THE FACTORY FOR PROJECT SPECIFIC ESTIMATES IF ADDITIONAL OPTIONS OR ACCESSORIES ARE REQUIRED.
  - SAFETY RELIEF VALVE SIZING IS BASED ON 100 PSIG TRIM. OTHER TRIM PRESSURES WILL CHANGE SAFETY VALVE SIZE.

REV	REVISION DESCRIPTION	B.O.M.	ELEC. ENG	MECH. ENG	CHECKED	APPROVED
-	INITIAL RELEASE	----	----	----	----	----
REVISION HISTORY						

UNLESS OTHERWISE NOTED, DIMENSIONS ARE IN INCHES.  
 TOLERANCES:  
 FRACTION & WHOLE VALUE ± 1/8  
 (1) PLACE DEC. ± 0.03  
 (2) PLACE DEC. ± 0.015  
 (3) PLACE DEC. ± 0.005  
 ANGLE ± 0.5 DEG  
 SURFACE FINISH 250 MICRO-INCHES

This design and drawings are proprietary and are the exclusive property of Fulton Group N.A., Inc. The corporation does not permit their use except with prior written consent.

The items shown in this drawing may be covered by one or more patents of Fulton Group N.A., Inc.

THIRD ANGLE PROJECTION  
 1 OF 1

DRAWN BY: C. AUSTIN 7/21/2016	MECH. ENG: EBW 7/28/2016	JOB NUMBER:
CHECKED BY:	ELEC. ENG:	PROJECT NAME:
B.O.M. REVIEW	APPROVED BY: WW 7/29/2016	PROJECT MANAGER:

DESCRIPTION:  
**FB-108E 108 KW HIGH PRESSURE ELECTRIC STEAM BOILER (100 PSI DESIGN)**

Fulton Group N.A., Inc  
 972 Centerville Road  
 Pulaski, New York USA 13142

DRAWING NUMBER: **9-FBE-108PDS**

SHEET 1 OF 1

REV: -