

SCOTT MODEL TBM TENDER BLEND CONTINUOUS MIXER



The Scott model TBM Tender Blend is a continuous process mixer that is designed to mix products with larger particle sizes such as pellets, flakes, whole or textured grains. The Tender Blend mixer is designed to delicately process materials which must be mixed and yet not damaged during the mixing process. The mixer is also ideal for combining liquids with coarse products. Coating particles with a liquid addition system. Because of the unique design of the Tender Blend and the variations of RPM that can be accomplished in the design of the Tender Blend, the mixer is ideal for applications such as textured animal feed, pelleted or flaked plastics, granulated fertilizers, textured or flaked food products.

The unique design on the agitator protects the integrity of the product during the mixing process. It is also available with adjustable retention times that allows the mixing production rate and retention time to be adjusted for varying product requirements.

The Scott TBM Tender Blend is available in carbon, stainless or a variety of other materials of construction with sanitary features available also as an option.

The standard design of the Tender Blend is to be used in a continuous application. In many cases, the unit will replace a batch mixer where the process can be modified to better suit a continuous process design. The standard design Tender Blend machine is designed proportionately to have one minute of retention time in the mixer with low agitation on the product to minimize damage or product degradation during the processing of the materials. The Tender Blend is available with optional full drop bottom clean out doors. Liquid addition systems can be supplied as an option. A wide assortment of feeding devices can also be supplied in a system with the Tender Blend mixer.

Advantages Of Continuous Mixing

There are many applications where the continuous process works better than the batch system. When the following conditions exist continuous mixing may be the best system.

- The number of ingredients are limited. Two to six ingredients usually work very well.
- The product is produced in fairly long runs without ingredient changes.
- The ingredients used in the product are in reasonably large amounts. Micro ingredients may need to be diluted to increase the volume used in the total mix.
- If the total process in the plant is continuous then the mixing process should be evaluated.
- Because the continuous mixer is small and holds a small amount of material at one time, clean up is much easier.

TENDER BLENDER DIMENSIONS (INCHES)

MODEL	A	B	C	D	E	F	G	H
16" x 84"	7	84	21½	7	8	10	25¼	6
20" x 96"	13	96	26½	13	10	14	30	8
24" x 120"	15	120	30½	15	10	16	35	8
30" x 144"	21	144	36	21	12	20	42	8
36" x 156"	7	156	42	24	12	24	48	10
42" x 168"	7	168	48	27	14	27	54	10
48" x 180"	7	180	54	30	16	30	60	10

NOTE: INLET & DISCHARGE SIZES MAY VARY TO FIT CUSTOMER NEEDS.

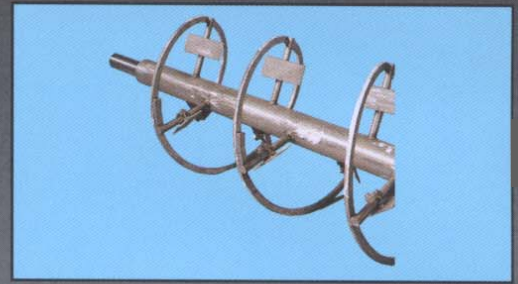
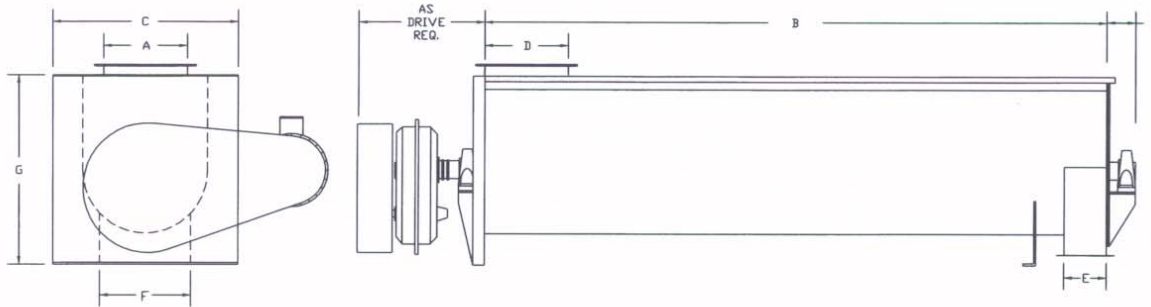

The paddle design in combination with the outside ribbon combines to deliver a gentle yet accurate mix. The paddles are adjustable to increase or decrease the intensity of the mix as well as the fill rate and retention time in the mixer.



Drive assembly as supplied is standard AGMA Class II design with a wide variety of motor and motor control options available.



Liquid manifold can be externally mounted or as a special spray chamber near the inlet of the mixer.



SCOTT
EQUIPMENT COMPANY

605 Fourth Avenue Northwest
New Prague, MN 56071

952-758-2591

Fax: 952-758-4377

Web Site: www.scottequipment.com

Call toll free 1-800-264-9519

**After all, you wouldn't want
to mix us up with anyone else.**